

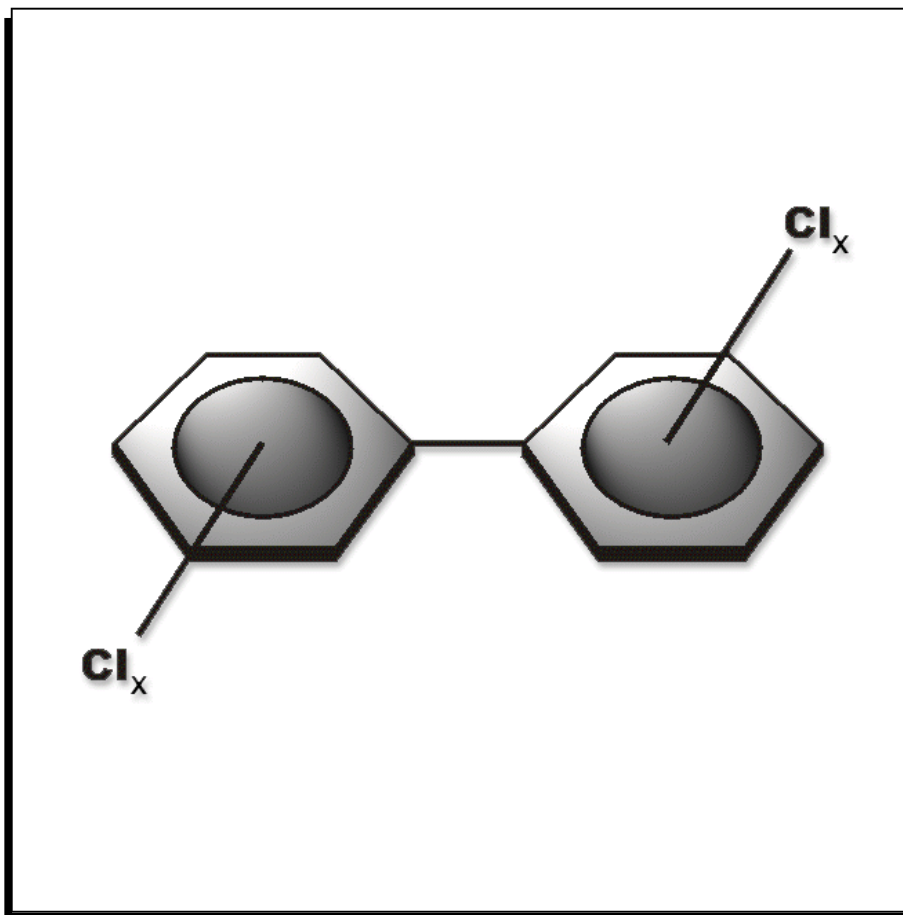

Method 1668, Revision A: Chlorinated Biphenyl Congeners in Water, Soil, Sediment, and Tissue by HRGC/HRMS



Acknowledgments

EPA Method 1668, Revision A (Method 1668A; the Method) was prepared under the direction of William A. Telliard of the Engineering and Analysis Division within EPA's Office of Water. Additional assistance in preparing the method was provided by DynCorp Information and Enterprise Technology and Interface, Inc.

Disclaimer

Method 1668A has been reviewed and approved for publication by the Engineering and Analysis Division of the U.S. Environmental Protection Agency. Mention of trade names or commercial products does not constitute endorsement or recommendation for use.

Table of Contents

Introduction	v
1.0 Scope and application	1
2.0 Summary of Method	2
3.0 Definitions	4
4.0 Contamination and Interferences	4
5.0 Safety	6
6.0 Apparatus and materials	8
7.0 Reagents and standards	16
8.0 Sample collection, preservation, and storage	24
9.0 Quality Control	25
10.0 Calibration	30
11.0 Sample preparation	35
12.0 Extraction and concentration	41
13.0 Extract cleanup	51
14.0 HRGC/HRMS analysis	57
15.0 System and laboratory performance	57
16.0 Qualitative determination	60
17.0 Quantitative determination	61
18.0 Analysis of complex samples	64
19.0 Pollution prevention	65
20.0 Waste management	66

Table of Contents (continued)

21.0	Method performance	66
22.0	References	67
23.0	Tables and Figures	69
24.0	Glossary	108
Annex A	A1

Introduction

Method 1668 was developed by the U.S. Environmental Protection Agency's (EPA's) Office of Science and Technology for congener-specific determination of the polychlorinated biphenyl (PCB) congeners designated as toxic by the World Health Organization. Revision A of Method 1668 has been expanded to include congener-specific determination of more than 150 chlorinated biphenyl (CB) congeners. The toxic PCBs and the beginning and ending level-of-chlorination CBs are determined by isotope dilution high resolution gas chromatography/high resolution mass spectrometry (HRGC/HRMS). The remaining CBs are determined by internal standard HRGC/HRMS. Method 1668A is applicable to aqueous, solid, tissue, and multi-phase matrices.

Method 1668A is based on validation in a single laboratory. The basic revision of Method 1668 was validated in two laboratories.

Questions concerning this method or its application should be addressed to:

William A. Telliard
Analytical Methods Staff (4303)
Office of Science and Technology
U.S. Environmental Protection Agency
401 M Street, SW
Washington, DC 20460
Phone: 202/260-7134
Fax: 202/260-7185

Note: This method is performance based. The laboratory is permitted to omit any step or modify any procedure provided that all performance requirements in this method are met. The laboratory may not omit any quality control analyses. The terms "shall," "must," and "may not" define procedures required for producing reliable results. The terms "should" and "may" indicate optional steps that may be modified or omitted if the laboratory can demonstrate that the modified method produces results equivalent or superior to results produced by this method.

Method 1668, Revision A

Chlorinated biphenyl congeners in water, soil, sediment, biosolids and tissue by HRGC/HRMS

1.0 Scope and application

- 1.1** Method 1668, Revision A (Method 1668A; the Method) is for determination of chlorinated biphenyl congeners (CBs) in water, soil, sediment, biosolids, tissue, and other sample matrices by high resolution gas chromatography/high resolution mass spectrometry (HRGC/HRMS).
- 1.1.1** The CBs that can be determined by this Method are the 12 polychlorinated biphenyls (PCBs) designated as toxic by the World Health Organization (WHO) plus the remaining 197 CBs, approximately 125 of which are resolved adequately on an SPB-octyl gas chromatographic column to be determined as individual congeners. The remaining approximately 70 congeners are determined as mixtures of isomers (co-elutions).
- 1.1.2** The 12 PCBs designated as toxic by WHO (Toxics; also known as dioxin-like PCBs; DLPCBs) and the earliest and latest eluted congener at each level of chlorination (LOC CBs) are determined by the isotope dilution quantitation technique; the remaining congeners are determined by the internal standard quantitation technique.
- 1.1.3** This Method allows determination of the PCB toxicity equivalent (TEQ_{PCB}) for the Toxics in a sample using toxicity equivalency factors (TEFs; Reference 1) and allows unique determination of 19 of 21 CBs of interest to the National Oceanic and Atmospheric Administration (NOAA; Reference 2). A second-column option is provided for resolution of the two toxic PCB congeners (with IUPAC numbers 156 and 157) that are not resolved on the SPB-octyl column and for resolution of other CB congeners.
- 1.1.4** This Method also allows estimation of homolog totals by level of chlorination (LOC) and estimation of total CBs in a sample by summation of the concentrations of the CB congeners and congener groups.
- 1.1.5** The list of 209 CBs is given in Table 1 with the Toxics, the CBs of interest to NOAA, and the LOC CBs identified.
- 1.2** This Method is for use in data gathering and monitoring associated with the Clean Water Act, the Resource Conservation and Recovery Act, the Comprehensive Environmental

Response, Compensation and Liability Act, and the Safe Drinking Water Act. It is based on a compilation of methods from the technical literature (References 3-5) and on EPA Method 1613.

- 1.3** The detection limits and quantitation levels in this Method are usually dependent on the level of interferences and laboratory background levels rather than instrumental limitations. The estimated minimum levels of quantitation (EMLs) in Table 2 are the levels at which the CBs can be determined with laboratory contamination present. The estimated method detection limit (EMDL) for CB 126 in water is 5 pg/L (picograms-per-liter; parts-per-quadrillion) with no interferences present.
- 1.4** The GC/MS portions of this Method are for use only by analysts experienced with HRGC/HRMS or under the close supervision of such qualified persons. Each laboratory that uses this Method must demonstrate the ability to generate acceptable results using the procedure in Section 9.2.
- 1.5** This Method is "performance-based." The laboratory is permitted to modify the Method to overcome interferences or lower the cost of measurements, provided that all performance criteria are met. The requirements for establishing Method equivalency are given in Section 9.1.2.
- 1.6** Any modification of this Method, beyond those expressly permitted, shall be considered a major modification subject to application and approval of alternate test procedures under 40 CFR 136.4 and 136.5.

2.0 Summary of Method

Flow charts that summarize procedures for sample preparation, extraction, and analysis are given in Figure 1 for aqueous and solid samples, Figure 2 for multi-phase samples, and Figure 3 for tissue samples.

2.1 Extraction

- 2.1.1** Aqueous samples (samples containing less than one percent solids)—Stable isotopically labeled analogs of the Toxics and labeled LOC CBs are spiked into a 1-L sample. The sample is extracted using solid-phase extraction (SPE), separatory funnel extraction (SFE), or continuous liquid/liquid extraction (CLLE).
- 2.1.2** Solid, semi-solid, and multi-phase samples (excluding tissue)—The labeled compounds are spiked into a sample containing 10 g (dry weight) of solids. Samples containing multiple phases are pressure filtered and any aqueous liquid is discarded. Coarse solids are ground or homogenized. Any non-aqueous liquid from multi-phase samples is combined with the solids and extracted in a Soxhlet/Dean-Stark (SDS) extractor. The extract is concentrated for cleanup.

- 2.1.3** Fish and other tissue—A 20-g aliquot of sample is homogenized, and a 10-g aliquot is spiked with the labeled compounds. The sample is mixed with anhydrous sodium sulfate, allowed to dry for 12 - 24 hours, and extracted for 18-24 hours using methylene chloride:hexane (1:1) in a Soxhlet extractor. The extract is evaporated to dryness, and the lipid content is determined.
- 2.2** After extraction, a labeled cleanup standard is spiked into the extract which is then cleaned up using back-extraction with sulfuric acid and/or base, and gel permeation, silica gel, or Florisil chromatography. Activated carbon and high-performance liquid chromatography (HPLC) can be used for further isolation of specific congener groups. Prior to the cleanup procedures cited above, tissue extracts are cleaned up using an anthropogenic isolation column.
- 2.3** After cleanup, the extract is concentrated to 20 μ L. Immediately prior to injection, labeled injection internal standards are added to each extract and an aliquot of the extract is injected into the gas chromatograph (GC). The analytes are separated by the GC and detected by a high-resolution ($\geq 10,000$) mass spectrometer. Two exact m/z's are monitored at each level of chlorination (LOC) throughout a pre-determined retention time window.
- 2.4** An individual CB congener is identified by comparing the GC retention time and ion-abundance ratio of two exact m/z's with the corresponding retention time of an authentic standard and the theoretical or acquired ion-abundance ratio of the two exact m/z's. Isomer specificity for certain of the CB congeners is achieved using GC columns that resolve these congeners.
- 2.5** Quantitative analysis is performed in one of two ways using selected ion current profile (SICP) areas:
- 2.5.1** For the Toxics and the LOC CBs, the GC/MS is multi-point calibrated and the concentration is determined using the isotope dilution technique.
- 2.5.2** For all congeners other than the Toxics and LOC CBs, the GC/MS is calibrated at a single concentration and the concentrations are determined using the internal standard technique.
- 2.5.3** For the labeled Toxics, labeled LOC CBs, and the cleanup standards, the GC/MS is calibrated using replicates at a single concentration and the concentrations of these labeled compounds in samples are determined using the internal standard technique.
- 2.6** The quality of the analysis is assured through reproducible calibration and testing of the extraction, cleanup, and GC/MS systems.

3.0 Definitions

Definitions are given in the glossary at the end of this Method.

4.0 Contamination and interferences

- 4.1** Solvents, reagents, glassware, and other sample processing hardware may yield artifacts, elevated baselines, and/or lock-mass suppression causing misinterpretation of chromatograms. Specific selection of reagents and purification of solvents by distillation in all-glass systems may be required. Where possible, reagents are cleaned by extraction or solvent rinse. Environmentally abundant CBs, as well as toxic congeners 105, 114, 118, 123, 156, 157, and 167 have been shown to be very difficult to completely eliminate from the laboratory at levels lower than the EMDLs in this Method (Table 2), and baking of glassware in a kiln or furnace at 450 - 500 °C may be necessary to remove these and other contaminants.
- 4.2** Proper cleaning of glassware is extremely important, because glassware may not only contaminate the samples but may also remove the analytes of interest by adsorption on the glass surface.
- 4.2.1** Glassware should be rinsed with solvent and washed with a detergent solution as soon after use as is practical. Sonication of glassware containing a detergent solution for approximately 30 seconds may aid in cleaning. Glassware with removable parts, particularly separatory funnels with fluoropolymer stopcocks, must be disassembled prior to detergent washing.
- 4.2.2** After detergent washing, glassware should be rinsed immediately, first with methanol, then with hot tap water. The tap water rinse is followed by another methanol rinse, then acetone, and then methylene chloride.
- 4.2.3** Baking of glassware in a kiln or other high temperature furnace (300 - 500 °C) may be warranted after particularly dirty samples are encountered. The kiln or furnace should be vented to prevent laboratory contamination by CB vapors. Baking should be minimized, as repeated baking of glassware may cause active sites on the glass surface that may irreversibly adsorb CBs.
- 4.2.4** Immediately prior to use, the Soxhlet apparatus should be pre-extracted with toluene for approximately 3 hours (see Sections 12.3.1-12.3.3). The extraction apparatus (Section 6.4) should be rinsed with methylene chloride/toluene (80/20 mixture).
- 4.2.5** A separate set of glassware may be necessary to effectively preclude contamination when low-level samples are analyzed.

- 4.3** All materials used in the analysis must be demonstrated to be free from interferences by running reference matrix method blanks (Section 9.5) initially and with each sample batch (samples started through the extraction process on a given 12-hour shift, to a maximum of 20 samples).
- 4.3.1** The reference matrix must simulate, as closely as possible, the sample matrix under test. Ideally, the reference matrix should not contain the CBs in detectable amounts, but should contain potential interferents in the concentrations expected to be found in the samples to be analyzed.
- 4.3.2** When a reference matrix that simulates the sample matrix under test is not available, reagent water (Section 7.6.1) can be used to simulate water samples; playground sand (Section 7.6.2) or white quartz sand (Section 7.3.2) can be used to simulate soils; filter paper (Section 7.6.3) can be used to simulate papers and similar materials; and corn oil (Section 7.6.4) can be used to simulate tissues.
- 4.4** Interferences co-extracted from samples will vary considerably from source to source, depending on the diversity of the site being sampled. Interfering compounds may be present at concentrations several orders of magnitude higher than the CBs. The most frequently encountered interferences are chlorinated dioxins and dibenzofurans, methoxy biphenyls, hydroxydiphenyl ethers, benzylphenyl ethers, brominated diphenyl ethers, polynuclear aromatics, polychlorinated naphthalenes, and pesticides. Because very low levels of CBs are measured by this Method, the elimination of interferences is essential. The cleanup steps given in Section 13 can be used to reduce or eliminate these interferences and thereby permit reliable determination of the CBs at the levels shown in Table 2.
- 4.5** Each piece of reusable glassware should be numbered to associate that glassware with the processing of a particular sample. This will assist the laboratory in tracking possible sources of contamination for individual samples, identifying glassware associated with highly contaminated samples that may require extra cleaning, and determining when glassware should be discarded.
- 4.6** Contamination of calibration solutions—The EMDLs and EMLs in Table 2 are the levels that can be achieved with normal laboratory backgrounds present. Many of the EMLs are greater than the equivalent concentrations of the calibration solutions. In order to prevent contamination of the calibration solutions with the backgrounds allowed by the EMLs, the calibration solutions must be prepared in an area free from CB contamination using glassware free from contamination. If these requirements cannot be met or are difficult to meet in the laboratory, the laboratory should prepare the calibration solutions in a contamination-free facility or have a vendor prepare the calibration standards and guarantee freedom from contamination.
- 4.7** Cleanup of tissue—The natural lipid content of tissue can interfere in the analysis of tissue samples for the CBs. The lipid contents of different species and portions of tissue

can vary widely. Lipids are soluble to varying degrees in various organic solvents and may be present in sufficient quantity to overwhelm the column chromatographic cleanup procedures used for cleanup of sample extracts. Lipids must be removed by the anthropogenic isolation column procedure in Section 13.6, followed by the gel permeation chromatography procedure in Section 13.2. Florisil (Section 13.7) is recommended as an additional cleanup step.

- 4.8** If the laboratory air is a potential source of CB contamination, samples, reagents, glassware, and other materials should be dried in a glove box or other area free from contamination.

5.0 Safety

- 5.1** The toxicity or carcinogenicity of each chemical used in this Method has not been precisely determined; however, each compound should be treated as a potential health hazard. Exposure to these compounds should be reduced to the lowest possible level.

5.1.1 PCBs have been tentatively classified as known or suspected human or mammalian carcinogens. On the basis of the available toxicological and physical properties of the CBs, pure standards should be handled only by highly trained personnel thoroughly familiar with handling and cautionary procedures and the associated risks.

5.1.2 It is recommended that the laboratory purchase dilute standard solutions of the analytes in this Method. However, if primary solutions are prepared, they must be prepared in a hood, and a NIOSH/MESA approved toxic gas respirator must be worn when high concentrations are handled.

- 5.2** The laboratory is responsible for maintaining a current awareness file of OSHA regulations regarding the safe handling of the chemicals specified in this Method. A reference file of material safety data sheets (MSDSs) should also be made available to all personnel involved in these analyses. It is also suggested that the laboratory perform personal hygiene monitoring of each analyst who uses this Method and that the results of this monitoring be made available to the analyst. Additional information on laboratory safety can be found in References 6-9. The references and bibliography at the end of Reference 8 are particularly comprehensive in dealing with the general subject of laboratory safety.

- 5.3** The pure CBs and samples suspected to contain these compounds are handled using essentially the same techniques employed in handling radioactive or infectious materials. Well-ventilated, controlled access laboratories are required. Assistance in evaluating the health hazards of particular laboratory conditions may be obtained from certain consulting laboratories and from State Departments of Health or Labor, many of which have an industrial health service. Each laboratory must develop a strict safety program for handling these compounds. The practices in Reference 10 for handling chlorinated

dibenzo-*p*-dioxins and dibenzofurans (CDDs/CDFs) are also recommended for handling the CBs.

- 5.3.1** Facility—When finely divided samples (dusts, soils, dry chemicals) are handled, all operations (including removal of samples from sample containers, weighing, transferring, and mixing) should be performed in a glove box demonstrated to be leak tight or in a fume hood demonstrated to have adequate air flow. Gross losses to the laboratory ventilation system must not be allowed. Handling of the dilute solutions normally used in analytical and animal work presents no inhalation hazards except in the case of an accident.
- 5.3.2** Protective equipment—Disposable plastic gloves, apron or lab coat, safety glasses or mask, and a glove box or fume hood adequate for radioactive work should be used. During analytical operations that may give rise to aerosols or dusts, personnel should wear respirators equipped with activated carbon filters. Eye protection (preferably full face shields) must be worn while working with exposed samples or pure analytical standards. Latex gloves are commonly used to reduce exposure of the hands. When handling samples suspected or known to contain high concentrations of the CBs, an additional set of gloves can also be worn beneath the latex gloves.
- 5.3.3** Training—Workers must be trained in the proper method of removing contaminated gloves and clothing without contacting the exterior surfaces.
- 5.3.4** Personal hygiene—Hands and forearms should be washed thoroughly after each manipulation and before breaks (coffee, lunch, and shift).
- 5.3.5** Confinement—Isolated work areas posted with signs, segregated glassware and tools, and plastic absorbent paper on bench tops will aid in confining contamination.
- 5.3.6** Effluent vapors—The effluent of the sample splitter from the gas chromatograph (GC) and from roughing pumps on the mass spectrometer (MS) should pass through either a column of activated charcoal or be bubbled through a trap containing oil or high-boiling alcohols to condense CB vapors.
- 5.3.7** Waste Handling—Good technique includes minimizing contaminated waste. Plastic bag liners should be used in waste cans. Janitors and other personnel should be trained in the safe handling of waste.
- 5.3.8** Decontamination.
 - 5.3.8.1** Decontamination of personnel—Use any mild soap with plenty of scrubbing action.

- 5.3.8.2** Glassware, tools, and surfaces—Chlorothene NU Solvent is a less toxic solvent that should be effective in removing CBs. Satisfactory cleaning may be accomplished by rinsing with Chlorothene, then washing with any detergent and water. If glassware is first rinsed with solvent, the wash water may be disposed of in the sewer. Given the cost of disposal, it is prudent to minimize solvent wastes.
- 5.3.9** Laundry—Clothing known to be contaminated should be collected in plastic bags. Persons that convey the bags and launder the clothing should be advised of the hazard and trained in proper handling. The clothing may be put into a washer without contact if the launderer knows of the potential problem. The washer should be run through a cycle before being used again for other clothing.
- 5.3.10** Wipe tests—A useful method of determining cleanliness of work surfaces and tools is to perform a wipe test of the surface suspected of being contaminated.
- 5.3.10.1** Using a piece of filter paper moistened with Chlorothene or other solvent, wipe an area approximately 10 x 10 cm.
- 5.3.10.2** Extract and analyze the wipe by GC with an electron capture detector (ECD) or by this Method.
- 5.3.10.2** Using the area wiped (e.g., 10 x 10 cm = 0.01 m²), calculate the concentration in $\mu\text{g}/\text{m}^2$. A concentration less than 1 $\mu\text{g}/\text{m}^2$ indicates acceptable cleanliness; anything higher warrants further cleaning. More than 100 $\mu\text{g}/\text{m}^2$ constitutes an acute hazard and requires prompt cleaning before further use of the equipment or work space, and indicates that unacceptable work practices have been employed.

6.0 Apparatus and materials

Note: *Brand names, suppliers, and part numbers are for illustration purposes only and no endorsement is implied. Equivalent performance may be achieved using apparatus and materials other than those specified here. Meeting the performance requirements of this Method is the responsibility of the laboratory.*

6.1 Sampling equipment for discrete or composite sampling

6.1.1 Sample bottles and caps.

- 6.1.1.1** Liquid samples (waters, sludges and similar materials containing 5 percent solids or less)—Sample bottle, amber glass, 1.1-L minimum, with screw cap.

- 6.1.1.2 Solid samples (soils, sediments, sludges, paper pulps, filter cake, compost, and similar materials that contain more than 5 percent solids)—Sample bottle, wide mouth, amber glass, 500-mL minimum.
- 6.1.1.3 If amber bottles are not available, samples must be protected from light.
- 6.1.1.4 Bottle caps—Threaded to fit sample bottles. Caps must be lined with fluoropolymer.
- 6.1.1.5 Cleaning
 - 6.1.1.5.1 Bottles are detergent water washed, then solvent rinsed before use.
 - 6.1.1.5.2 Liners are detergent water washed and rinsed with reagent water (Section 7.6.1).

6.1.2 Compositing equipment—Automatic or manual compositing system incorporating glass containers cleaned per bottle cleaning procedure above. Only glass or fluoropolymer tubing must be used. If the sampler uses a peristaltic pump, a minimum length of compressible silicone rubber tubing may be used in the pump only. Before use, the tubing must be thoroughly rinsed with methanol, followed by repeated rinsing with reagent water to minimize sample contamination. An integrating flow meter is used to collect proportional composite samples.

6.2 Equipment for glassware cleaning

Note: *If blanks from bottles or other glassware or with fewer cleaning steps than required above show no detectable CB contamination, unnecessary cleaning steps and equipment may be eliminated.*

- 6.2.1 Laboratory sink with overhead fume hood
- 6.2.2 Kiln—Capable of reaching 450 °C within 2 hours and maintaining 450 - 500 °C within ± 10 °C, with temperature controller and safety switch (Cress Manufacturing Co, Santa Fe Springs, CA, B31H, X31TS, or equivalent). See the precautions in Section 4.2.3.

6.3 Equipment for sample preparation

- 6.3.1** Laboratory fume hood of sufficient size to contain the sample preparation equipment listed below.
- 6.3.2** Glove box (optional)
- 6.3.3** Tissue homogenizer—VirTis Model 45 Macro homogenizer (American Scientific Products H-3515, or equivalent) with stainless steel Macro-shaft and Turbo-shear blade.
- 6.3.4** Meat grinder—Hobart, or equivalent, with 3- to 5-mm holes in inner plate.
- 6.3.5** Equipment for determining percent moisture
 - 6.3.5.1** Oven—Capable of maintaining a temperature of 110 ± 5 °C
 - 6.3.5.2** Desiccator
- 6.3.6** Balances
 - 6.3.6.1** Analytical—Capable of weighing 0.1 mg
 - 6.3.6.2** Top loading—Capable of weighing 10 mg
- 6.4** Extraction apparatus
 - 6.4.1** Water samples
 - 6.4.1.1** pH meter, with combination glass electrode
 - 6.4.1.2** pH paper, wide range (Hydrion Papers, or equivalent)
 - 6.4.1.3** Graduated cylinder, 1-L capacity
 - 6.4.1.4** Liquid/liquid extraction—Separatory funnels, 250-, 500-, and 2000-mL, with fluoropolymer stopcocks
 - 6.4.1.5** Solid-phase extraction
 - 6.4.1.5.1** 1-L filtration apparatus, including glass funnel, frit support, clamp, adapter, stopper, filtration flask, and vacuum tubing (Figure 4). For wastewater samples, the apparatus should accept 90 or 144 mm disks. For drinking water or other samples containing low solids, smaller disks may be used.

- 6.5.3** Glass-fiber filter paper—Whatman GF/D (or equivalent), to fit glass funnel in Section 6.5.2.
- 6.5.4** Drying column—15- to 20-mm ID Pyrex chromatographic column equipped with coarse-glass frit or glass-wool plug
- 6.5.5** Buchner funnel—15-cm
- 6.5.6** Glass-fiber filter paper for Buchner funnel above
- 6.5.7** Filtration flasks—1.5- to 2.0-L, with side arm
- 6.5.8** Pressure filtration apparatus—Millipore YT30 142 HW, or equivalent
- 6.6** Centrifuge apparatus
 - 6.6.1** Centrifuge—Capable of rotating 500-mL centrifuge bottles or 15-mL centrifuge tubes at 5,000 rpm minimum
 - 6.6.2** Centrifuge bottles—500-mL, with screw-caps, to fit centrifuge
 - 6.6.3** Centrifuge tubes—12- to 15-mL, with screw-caps, to fit centrifuge
- 6.7** Cleanup apparatus
 - 6.7.1** Automated gel permeation chromatograph (Analytical Biochemical Labs, Inc, Columbia, MO, Model GPC Autoprep 1002, or equivalent)
 - 6.7.1.1** Column—600-700 mm long × 25 mm ID glass, packed with 70 g of 200-400 mesh SX-3 Bio-beads (Bio-Rad Laboratories, Richmond, CA, or equivalent)
 - 6.7.1.2** Syringe—10-mL, with Luer fitting
 - 6.7.1.3** Syringe filter holder—stainless steel, and glass-fiber or fluoropolymer filters (Gelman 4310, or equivalent)
 - 6.7.1.4** UV detectors—254-nm, preparative or semi-preparative flow cell (Isco, Inc., Type 6; Schmadzu, 5-mm path length; Beckman-Altex 152W, 8- μ L micro-prep flow cell, 2-mm path; Pharmacia UV-1, 3-mm flow cell; LDC Milton-Roy UV-3, monitor #1203; or equivalent)xxx
 - 6.7.2** Reverse-phase high-performance liquid chromatograph (Reference 4)

- 6.7.2.1** Pump—Perkin-Elmer Series 410, or equivalent
- 6.7.2.2** Injector—Perkin-Elmer ISS-100 Autosampler, or equivalent
- 6.7.2.3** 6-Port switching valve—Valco N60, or equivalent
- 6.7.2.4** Column—Hypercarb, 100 x 4.6 mm, 5 μ m particle size, Keystone Scientific, or equivalent
- 6.7.2.5** Detector—Altex 110A (or equivalent) operated at 0.02 AUFS at 235 nm
- 6.7.2.6** Fraction collector—Isco Foxy II, or equivalent
- 6.7.3** Pipets
 - 6.7.3.1** Disposable, Pasteur, 150-mm long \times 5-mm ID (Fisher Scientific 13-678-6A, or equivalent)
 - 6.7.3.2** Disposable, serological, 50-mL (8- to 10- mm ID)
- 6.7.4** Glass chromatographic columns
 - 6.7.4.1** 150-mm long \times 8-mm ID, (Kontes K-420155, or equivalent) with coarse-glass frit or glass-wool plug and 250-mL reservoir
 - 6.7.4.2** 200-mm long \times 15-mm ID, with coarse-glass frit or glass-wool plug and 250-mL reservoir
 - 6.7.4.3** 300-mm long \times 22-mm ID, with coarse-glass frit, 300-mL reservoir, and glass or fluoropolymer stopcock
- 6.7.5** Oven—For baking and storage of adsorbents, capable of maintaining a constant temperature (± 5 °C) in the range of 105-250 °C
- 6.8** Concentration apparatus
 - 6.8.1** Rotary evaporator—Buchi/Brinkman-American Scientific No. E5045-10 or equivalent, equipped with a variable temperature water bath
 - 6.8.1.1** Vacuum source for rotary evaporator equipped with shutoff valve at the evaporator and vacuum gauge
 - 6.8.1.2** A recirculating water pump and chiller are recommended, as use of tap water for cooling the evaporator wastes large volumes of water

and can lead to inconsistent performance as water temperatures and pressures vary.

6.8.1.3 Round-bottom flask—100-mL and 500-mL or larger, with ground-glass fitting compatible with the rotary evaporator

6.8.2 Kuderna-Danish (K-D) concentrator

6.8.2.1 Concentrator tube—10-mL, graduated (Kontes K-570050-1025, or equivalent) with calibration verified. Ground-glass stopper (size 19/22 joint) is used to prevent evaporation of extracts.

6.8.2.2 Evaporation flask—500-mL (Kontes K-570001-0500, or equivalent), attached to concentrator tube with springs (Kontes K-662750-0012 or equivalent)

6.8.2.3 Snyder column—Three-ball macro (Kontes K-503000-0232, or equivalent)

6.8.2.4 Boiling chips

6.8.2.4.1 Glass or silicon carbide—Approximately 10/40 mesh, extracted with methylene chloride and baked at 450 °C for one hour minimum

6.8.2.4.2 Fluoropolymer (optional)—Extracted with methylene chloride

6.8.2.5 Water bath—Heated, with concentric ring cover, capable of maintaining a temperature within ± 2 °C, installed in a fume hood

6.8.3 Nitrogen blowdown apparatus—Equipped with water bath controlled in the range of 30 - 60 °C (N-Evap, Organomation Associates, Inc., South Berlin, MA, or equivalent), installed in a fume hood

6.8.4 Sample vials

6.8.4.1 Amber glass, 2- to 5-mL with fluoropolymer-lined screw-cap

6.8.4.2 Glass, 0.3-mL, conical, with fluoropolymer-lined screw or crimp cap

6.9 Gas chromatograph—Must have splitless or on-column injection port for capillary column, temperature program with isothermal hold, and must meet all of the performance specifications in Section 10.

-
- 6.9.1** GC column—Any GC column or column system (2 or more columns) that provides unique resolution and identification of the Toxics for determination of a TEQ_{PCB} using TEFs (Reference 1). Isomers may be unresolved so long as they have the same TEF and response factor and so long as these unresolved isomers are uniquely resolved from all other congeners. For example, the SPB-octyl column (Section 6.9.1.3) achieves unique GC resolution of all Toxics except congeners with IUPAC numbers 156 and 157. This isomeric pair is uniquely resolved from all other congeners and these congeners have the same TEF and response factor.
- 6.9.1.1** If an SPB-octyl column is used, it must meet the specification in Section 6.9.1 and the following additional specifications:
- 6.9.1.1.1** The retention time for decachlorobiphenyl (DFB; PCB 209) must be greater than 55 minutes.
- 6.9.1.1.2** The column must uniquely resolve congeners 34 from 23 and 187 from 182, and congeners 156 and 157 must co-elute within 2 seconds at the peak maximum. Unique resolution means a valley height less than 40 percent of the shorter of the two peaks that result when the Diluted combined 209 congener solution (Section 7.10.2.2) is analyzed (see Figures 6 and 7).
- 6.9.1.1.3** The column must be replaced when any of the criteria in Sections 6.9.1 - 6.9.1.1.2 are not met.
- 6.9.1.2** If a column or column system alternate to the SPB-octyl column is used, specifications similar to those for the SPB-octyl column (Sections 6.9.1 - 6.9.1.1.2) must be developed and be functionally equivalent to those specifications.
- 6.9.1.3** Suggested column— 30 ± 5 -m long \times 0.25 ± 0.02 -mm ID; $0.25\text{-}\mu\text{m}$ film SPB-octyl (Supelco 2-4218, or equivalent). This column is capable of meeting the requirements in Sections 6.9.1 - 6.9.1.1.2.

Note: *The SPB-octyl column is subject to rapid degradation when exposed to oxygen. The analyst should exclude oxygen from the carrier gas, should eliminate air leaks, and should cool the injector, column, and transfer line before opening the column to the atmosphere. For further information on precluding oxidation, contact the column manufacturer.*

- 6.9.1.4** Column for resolution of additional congeners—See Annex A for details on the DB-1 column. The DB-1 column is optional and is capable of uniquely resolving the congener pair with IUPAC

156 and 157. When used in combination with the SPB-octyl column (Section 6.9.1.3), the two-column system is capable of resolving a total of approximately 180 CB congeners.

- 6.10** Mass spectrometer—28- to 40-eV electron impact ionization, must be capable of selectively monitoring a minimum of 22 exact m/z's minimum at high resolution ($\geq 10,000$) during a period less than 1.5 seconds, and must meet all of the performance specifications in Section 10.
- 6.11** GC/MS interface—The mass spectrometer (MS) must be interfaced to the GC such that the end of the capillary column terminates within 1 cm of the ion source but does not intercept the electron or ion beams.
- 6.12** Data system—Capable of collecting, recording, storing, and processing MS data
 - 6.12.1** Data acquisition—The signal at each exact m/z must be collected repetitively throughout the monitoring period and stored on a mass storage device.
 - 6.12.2** Response factors and multipoint calibrations—The data system must record and maintain lists of response factors (response ratios for isotope dilution) and multipoint calibrations. Computations of relative standard deviation (RSD) are used to test calibration linearity. Statistics on initial (Section 9.4) and ongoing (Section 15.5.4) performance should be computed and maintained, either on the instrument data system, or on a separate computer system.

7.0 Reagents and standards

- 7.1** pH adjustment and back-extraction
 - 7.1.1** Potassium hydroxide—Dissolve 20 g reagent grade KOH in 100 mL reagent water.
 - 7.1.2** Sulfuric acid—Reagent grade (specific gravity 1.84)
 - 7.1.3** Hydrochloric acid—Reagent grade, 6N
 - 7.1.4** Sodium chloride—Reagent grade, prepare at 5% (w/v) solution in reagent water
- 7.2** Solution drying and evaporation
 - 7.2.1** Solution drying—Sodium sulfate, reagent grade, granular, anhydrous (Baker 3375, or equivalent), rinsed with methylene chloride (20 mL/g), baked at 400 °C for 1 hour minimum, cooled in a desiccator, and stored in a pre-cleaned glass bottle with screw-cap that prevents moisture from entering. If, after heating, the sodium sulfate develops a noticeable grayish cast (due to the presence of carbon

in the crystal matrix), that batch of reagent is not suitable for use and should be discarded. Extraction with methylene chloride (as opposed to simple rinsing) and baking at a lower temperature may produce sodium sulfate that is suitable for use.

7.2.2 Tissue drying—Sodium sulfate, reagent grade, powdered, treated and stored as in Section 7.2.1

7.2.3 Prepurified nitrogen

7.3 Extraction

7.3.1 Solvents—Acetone, toluene, cyclohexane, hexane, methanol, methylene chloride, isooctane, and nonane; distilled in glass, pesticide quality, lot-certified to be free of interferences

Note: *Some solvents; e.g., isooctane and nonane, may need to be re-distilled to eliminate CB backgrounds.*

7.3.2 White quartz sand, 60/70 mesh—For Soxhlet/Dean-Stark extraction (Aldrich Chemical, Cat. No. 27-437-9, or equivalent). Bake at 450 °C for 4 hour minimum.

7.4 GPC calibration solution—Prepare a solution containing 2.5 mg/mL corn oil, 0.05 mg/mL bis(2-ethylhexyl) phthalate (BEHP), 0.01 mg/mL methoxychlor, 0.002 mg/mL perylene, and 0.008 mg/mL sulfur, or at concentrations appropriate to the response of the detector.

7.5 Adsorbents for sample cleanup

7.5.1 Silica gel

7.5.1.1 Activated silica gel—100-200 mesh, Supelco 1-3651 (or equivalent), rinsed with methylene chloride, baked at 180 °C for a minimum of 1 hour, cooled in a desiccator, and stored in a precleaned glass bottle with screw-cap that prevents moisture from entering.

7.5.1.2 Acid silica gel (30% w/w)—Thoroughly mix 44 g of concentrated sulfuric acid with 100 g of activated silica gel in a clean container. Break up aggregates with a stirring rod until a uniform mixture is obtained. Store in a screw-capped bottle with fluoropolymer-lined cap.

- 7.5.1.3** Basic silica gel—Thoroughly mix 30 g of 1N sodium hydroxide with 100 g of activated silica gel in a clean container. Break up aggregates with a stirring rod until a uniform mixture is obtained. Store in a screw-capped bottle with fluoropolymer-lined cap.
- 7.5.1.4** Potassium silicate
 - 7.5.1.4.1** Dissolve 56 g of high purity potassium hydroxide (Aldrich, or equivalent) in 300 mL of methanol in a 750- to 1000-mL flat-bottom flask.
 - 7.5.1.4.2** Add 100 g of activated silica gel (Section 7.5.1.1) and a stirring bar, and stir on an explosion-proof hot plate at 60-70 °C for 1-2 hours.
 - 7.5.1.4.3** Decant the liquid and rinse the potassium silicate twice with 100-mL portions of methanol, followed by a single rinse with 100 mL of methylene chloride.
 - 7.5.1.4.4** Spread the potassium silicate on solvent-rinsed aluminum foil and dry for 2-4 hours in a hood. Observe the precaution in Section 4.8.
 - 7.5.1.4.5** Activate overnight at 200-250 °C prior to use.
- 7.5.2** Carbon
 - 7.5.2.1** Caropak C—(Supelco 1-0258, or equivalent)
 - 7.5.2.2** Celite 545—(Supelco 2-0199, or equivalent)
 - 7.5.2.3** Thoroughly mix 18.0 g Caropak C and 18.0 g Celite 545 to produce a 50% w/w mixture. Activate the mixture at 130 °C for a minimum of 6 hours. Store in a desiccator.

Note: *The carbon column has been included in this Method to allow separation of co-planar congeners 77, 126, and 169 from other congeners and interferences, should such separation be desired.*

- 7.5.3** Anthropogenic isolation column—Pack the column in Section 6.7.4.3 from bottom to top with the following:
 - 7.5.3.1** 2 g silica gel (Section 7.5.1.1)

- 7.5.3.2** 2 g potassium silicate (Section 7.5.1.4)
- 7.5.3.3** 2 g granular anhydrous sodium sulfate (Section 7.2.1)
- 7.5.3.4** 10 g acid silica gel (Section 7.5.1.2)
- 7.5.3.5** 2 g granular anhydrous sodium sulfate

7.5.4 Florisil column

7.5.4.1 Florisil—PR grade, 60-100 mesh (U.S. Silica Corp, Berkeley Springs, WV, or equivalent). Alternatively, prepacked Florisil columns may be used. Use the following procedure for Florisil activation and column packing.

7.5.4.1.1 Fill a clean 1- to 2-L bottle 1/2 to 2/3 full with Florisil and place in an oven at 130-150 °C for a minimum of three days to activate the Florisil.

7.5.4.1.2 Immediately prior to use, dry pack a 300-mm x 22-mm ID glass column (Section 6.7.4.3) bottom to top with 0.5-1.0 cm of warm to hot anhydrous sodium sulfate (Section 7.2.1), 10-10.5 cm of warm to hot activated Florisil (Section 7.5.4.1.1), and 1-2 cm of warm to hot anhydrous sodium sulfate. Allow the column to cool and wet immediately with 100 mL of n-hexane to prevent water from entering.

7.5.4.2 Using the procedure in Section 13.7.3, establish the elution pattern for each carton of Florisil or each lot of Florisil columns received.

7.6 Reference matrices—Matrices in which the CBs and interfering compounds are not detected by this Method

- 7.6.1** Reagent water—Bottled water purchased locally, or prepared by passage through activated carbon
- 7.6.2** High-solids reference matrix—Playground sand or similar material. Prepared by extraction with methylene chloride and/or baking at 450 °C for a minimum of 4 hours.
- 7.6.3** Paper reference matrix—Glass-fiber filter, Gelman type A, or equivalent. Cut paper to simulate the surface area of the paper sample being tested.
- 7.6.4** Tissue reference matrix—Corn or other vegetable oil.

- 7.6.5** Other matrices—This Method may be verified on any reference matrix by performing the tests given in Section 9.2. Ideally, the matrix should be free of the CBs, but in no case must the background level of the CBs in the reference matrix exceed the minimum levels in Table 2. If low background levels of the CBs are present in the reference matrix, the spike level of the analytes used in Section 9.2 should be increased to provide a spike-to-background ratio of approximately 5 (Reference 11).
- 7.7** Standard solutions—Prepare from materials of known purity and composition or purchase as solutions or mixtures with certification to their purity, concentration, and authenticity. If the chemical purity is 98 % or greater, the weight may be used without correction to calculate the concentration of the standard. Observe the safety precautions in Section 5 and the recommendation in Section 5.1.2.
- 7.7.1** For preparation of stock solutions from neat materials, dissolve an appropriate amount of assayed reference material in solvent. For example, weigh 1 to 2 mg of PCB 126 to three significant figures in a 10-mL ground-glass-stoppered volumetric flask and fill to the mark with nonane. After the compound is completely dissolved, transfer the solution to a clean 15-mL vial with fluoropolymer-lined cap.
- 7.7.2** When not being used, store standard solutions in the dark at room temperature in screw-capped vials with fluoropolymer-lined caps. Place a mark on the vial at the level of the solution so that solvent loss by evaporation can be detected. Replace the solution if solvent loss has occurred.
- 7.8** Native (unlabeled) stock solutions
- 7.8.1** Native Toxics/LOC stock solution—Prepare to contain the native Toxics and LOC CBs at the concentrations shown in Table 3, or purchase Accu-Standard M1668A-C-NT-LOC-WD-GCPC, or equivalent. If additional CBs are to be determined by isotope dilution (e.g., 170 and 180), include the additional native compounds in this stock solution.
- 7.8.2** Native 209 CB congener stock solutions—Solutions containing CB congeners to calibrate the SPB-octyl column.

Note: *If a column other than the SPB-octyl column is used, solutions that will allow separation of all 209 congeners on that column must be prepared.*

- 7.8.2.1** Native congener mix stock solutions for separation of individual congeners on the SPB-octyl column—Prepare the five solutions with the congeners listed in Table 4 at the concentrations shown in Table

3 or purchase Accu-Standard M-1668A-1, M-1668A-2, M-1668A-3, M-1668-4, and M-1668-5, or equivalent.

7.8.2.2 Combined 209 congener stock solution—Combine equal volumes of the standards in Section 7.8.2.1 to form a stock solution containing all CB congeners. This solution will be at 1/5 the concentration of the 5 individual solutions.

7.8.3 Stock solutions should be checked for signs of degradation prior to the preparation of calibration or performance test standards. Reference standards that can be used to determine the accuracy of standard solutions are available from several vendors.

7.9 Labeled compound stock solutions (Table 3)

7.9.1 Labeled Toxics/LOC/window-defining stock solution—Prepare in isooctane or nonane at the concentrations in Table 3 or purchase Cambridge Isotope Laboratories (CIL) EC-4977, or equivalent. If additional CBs are to be determined by isotope dilution (e.g., 170 and 180), include the additional labeled compounds in this stock solution.

7.9.2 Labeled cleanup standard stock solution—Prepare labeled CBs 28, 111, and 178 in iso-octane or nonane at the concentration shown in Table 3 or purchase CIL EC-4978, or equivalent.

7.9.3 Labeled injection internal standard stock solution—Prepare labeled CBs 9, 52, 101, 138, and 194 in nonane or isooctane at the concentrations shown in Table 3, or purchase CIL EC-4979, or equivalent.

7.10 Calibration standards

7.10.1 Calibration standards—Combine and dilute the solutions in Sections 7.8.1 and 7.9 to produce the calibration solutions in Table 5 or purchase CIL EC-4976, or equivalent, for the CS-1 to CS-5 set of calibration solutions. If a 6-point calibration is used, prepare the CS-0.2 solution or purchase CIL EC-4976-0.2, or equivalent. These solutions permit the relative response (labeled to native) and response factor to be measured as a function of concentration. The CS-3 standard (CIL EC-4976-3, or equivalent) is used for calibration verification (VER).

7.10.2 Solutions of congener mixes

7.10.2.1 Diluted individual solutions

7.10.2.1.1 The 5 individual solutions, when analyzed individually,

allow resolution of all 209 congeners on the SPB-octyl column, and are used for establishing retention time and other data for each congener. The elution order of the congeners present in each of the 5 solutions (Section 7.8.2.1) is given in Table 4.

7.10.2.1.2 Individually combine an aliquot of each individual mix stock solution (Section 7.8.2.1) with an aliquot of the Labeled Toxics/LOC/window-defining stock solution (Section 7.9.1), the Labeled cleanup standard stock solution (Section 7.9.2), and the Labeled injection internal standard stock solution (7.9.3) to produce concentrations of 100 ng/mL for the labeled compounds and 25, 50, and 75 ng/mL for the MoCB-TrCB, TeCB-HpCB, and OcCB-DeCB congeners, respectively, as shown in Table 3.

7.10.2.2 Diluted combined 209 congener solution

7.10.2.2.1 This solution combines the 5 individual mixes with the labeled compounds to allow single-point calibration of the congeners not included in the multi-point calibration, and establishes an average response factor for the co-eluting isomeric congeners.

7.10.2.2.2 Combine an aliquot of the combined 209 congener solution (Section 7.8.2.2) with an aliquot of the Labeled Toxics/LOC/window-defining stock solution (Section 7.9.1), the Labeled cleanup standard stock solution (Section 7.9.2), and the Labeled injection internal standard stock solution (7.9.3) to produce the same concentrations as in the diluted individual mix solutions (Section 7.10.2.1.2 and Table 3).

7.11 Native Toxics/LOC standard spiking solution—Used for determining initial precision and recovery (IPR; Section 9.2) and ongoing precision and recovery (OPR; Section 15.5). Dilute the Native Toxics/LOC stock solution (Section 7.8.1) with acetone to produce a concentration of the Toxics at 1 ng/mL, as shown in Table 3. When 1 mL of this solution spiked into the IPR (Section 9.2.1) or OPR (Section 15.5) and concentrated to a final volume of 20 μ L, the concentration in the final volume will be 50 ng/mL (50 pg/ μ L). Prepare only the amount necessary for each reference matrix with each sample batch.

7.12 Labeled Toxics/LOC/window-defining standard spiking solution—This solution is spiked into each sample (Section 9.3) and into the IPR (Section 9.2.1), OPR (Section

15.5), and blank (Section 9.5) to measure recovery. Dilute the Labeled Toxics/LOC/window-defining stock solution (Section 7.9.1) with acetone to produce a concentration of the labeled compounds at 2 ng/mL, as shown in Table 3. When 1 mL of this solution is spiked into an IPR, OPR, blank, or sample and concentrated to a final extract volume of 20 μ L, the concentration in the final extract volume will be 100 ng/mL (100 pg/ μ L). Prepare only the amount necessary for each reference matrix with each sample batch.

- 7.13** Labeled cleanup standard spiking solution—This solution is spiked into each extract prior to cleanup to measure the efficiency of the cleanup process. Dilute the Labeled cleanup standard stock solution (Section 7.9.2) in methylene chloride to produce a concentration of the cleanup standards at 2 ng/mL, as shown in Table 3. When 1 mL of this solution is spiked into a sample extract and concentrated to a final volume of 20 μ L, the concentration in the final volume will be 100 ng/mL (100 pg/ μ L).
- 7.14** Labeled injection internal standard spiking solution—This solution is added to each concentrated extract prior to injection into the HRGC/HRMS. Dilute the Labeled injection internal standard stock solution (Section 7.9.3) in nonane to produce a concentration of the injection internal standards at 1000 ng/mL, as shown in Table 3. When 2 μ L of this solution is spiked into a 20 μ L extract, the concentration of each injection internal standard will be nominally 100 ng/mL (100 pg/ μ L).

Note: *The addition of 2 μ L of the Labeled injection internal standard spiking solution to a 20 μ L final extract has the effect of diluting the concentration of the components in the extract by 10%. Provided all calibration solutions and all extracts undergo this dilution as a result of adding the Labeled injection internal standard spiking solution, the effect of the 10% solution is compensated, and correction for this dilution should not be made.*

- 7.15** QC Check Sample—A QC Check Sample should be obtained from a source independent of the calibration standards. Ideally, this check sample would be a certified Standard Reference Material (SRM) containing the CBs in known concentrations in a sample matrix similar to the matrix under test. The National Institute of Standards and Technology (NIST) in Gaithersburg, Maryland has SRMs for several individual CB congeners, and as Aroclors in transformer and motor oil, in combination with pesticides in cod liver oil, and in combination with 2,3,7,8-TCDD in human serum.
- 7.16** Stability of solutions—Standard solutions used for quantitative purposes (Sections 7.9 through 7.14) should be assayed periodically (e.g., every 6 months) against SRMs from NIST (if available), or certified reference materials from a source that will attest to the authenticity and concentration, to assure that the composition and concentrations have not changed.

8.0 Sample collection, preservation, storage, and holding times

- 8.1 Collect samples in amber glass containers following conventional sampling practices (Reference 13).
- 8.2 Aqueous samples
 - 8.2.1 Samples that flow freely are collected as grab samples or in refrigerated bottles using automatic sampling equipment.
 - 8.2.2 If residual chlorine is present, add 80 mg sodium thiosulfate per liter of water. EPA Methods 330.4 and 330.5 may be used to measure residual chlorine (Reference 14).
 - 8.2.3 Adjust sample pH 2-3 with sulfuric acid.
 - 8.2.4 Maintain aqueous samples in the dark at 0-4 °C from the time of collection until receipt at the laboratory. Store in the dark at 0-4 °C.
- 8.3 Solid samples
 - 8.3.4 Solid samples are collected as grab samples using wide-mouth jars.
 - 8.3.4 Maintain solid, semi-solid, oily, and mixed-phase samples in the dark at <4 °C from the time of collection until receipt at the laboratory. Store solid, semi-solid, oily, and mixed-phase samples in the dark at <-10 °C.
- 8.4 Fish and other tissue samples
 - 8.4.1 Fish may be cleaned, filleted, or processed in other ways in the field, such that the laboratory may expect to receive whole fish, fish fillets, or other tissues for analysis.
 - 8.4.2 Fish collected in the field should be wrapped in aluminum foil, and must be maintained at a temperature less than 4 °C from the time of collection until receipt at the laboratory. Ideally, fish should be frozen upon collection and shipped to the laboratory under dry ice.
 - 8.4.3 Tissue samples must be frozen upon receipt at the laboratory and maintained in the dark at <-10 °C until prepared. Maintain unused sample in the dark at <-10 °C.
- 8.5 Holding times
 - 8.5.1 There are no demonstrated maximum holding times associated with the CBs in

aqueous, solid, semi-solid, tissues, or other sample matrices. If stored in the dark at 0-4 °C and preserved as given above (if required), aqueous samples may be stored for up to one year. Similarly, if stored in the dark at <-10 °C, solid, semi-solid, multi-phase, and tissue samples may be stored for up to one year.

- 8.5.2** Store sample extracts in the dark at <-10 °C until analyzed. If stored in the dark at <-10 °C, sample extracts may be stored for up to one year.

9.0 Quality assurance/quality control

- 9.1** Each laboratory that uses this Method is required to operate a formal quality assurance program (Reference 15). The minimum requirements of this program consist of an initial demonstration of laboratory capability, analysis of samples spiked with labeled compounds to evaluate and document data quality, and analysis of standards and blanks as tests of continued performance. Laboratory performance is compared to established performance criteria to determine if the results of analyses meet the performance characteristics of the Method.

If the Method is to be applied to sample matrix other than water (e.g., soils, filter cake, compost, tissue) the most appropriate alternate reference matrix (Sections 7.6.2 - 7.6.5 and 7.15) is substituted for the reagent water matrix (Section 7.6.1) in all performance tests.

- 9.1.1** The laboratory must make an initial demonstration of the ability to generate acceptable precision and recovery with this Method. This demonstration is given in Section 9.2.
- 9.1.2** In recognition of advances that are occurring in analytical technology, and to overcome matrix interferences, the laboratory is permitted certain options to improve separations or lower the costs of measurements. These options include alternate extraction, concentration, and cleanup procedures, and changes in columns and detectors. Alternate determinative techniques, such as the substitution of spectroscopic or immuno-assay techniques, and changes that degrade Method performance, are not allowed. If an analytical technique other than the techniques specified in this Method is used, that technique must have a specificity equal to or greater than the specificity of the techniques in this Method for the analytes of interest.
- 9.1.2.1** Each time a modification is made to this Method, the laboratory is required to repeat the procedure in Section 9.2. If the detection limit of the Method will be affected by the change, the laboratory is required to demonstrate that the MDLs (40 CFR Part 136, Appendix B) are lower than one-third the regulatory compliance level or one-third the EMDLs in this Method, whichever are greater. If calibration will be affected by the change, the instrument must be

recalibrated per Section 10.

9.1.2.2 The laboratory is required to maintain records of modifications made to this Method. These records include the following, at a minimum:

9.1.2.2.1 The names, titles, addresses, and telephone numbers of the analyst(s) that performed the analyses and modification, and of the quality control officer that witnessed and will verify the analyses and modifications.

9.1.2.2.2 A listing of pollutant(s) measured, by name and CAS Registry number.

9.1.2.2.3 A narrative stating reason(s) for the modifications.

9.1.2.2.4 Results from all quality control (QC) tests comparing the modified method to this Method, including:

- a) Calibration (Section 10).
- b) Calibration verification (Section 15.3).
- c) Initial precision and recovery (Section 9.2).
- d) Labeled compound recovery (Section 9.3).
- e) Analysis of blanks (Section 9.5).
- f) Accuracy assessment (Section 9.4).

9.1.2.2.5 Data that will allow an independent reviewer to validate each determination by tracing the instrument output (peak height, area, or other signal) to the final result. These data are to include:

- a) Sample numbers and other identifiers.
- b) Extraction dates.
- c) Analysis dates and times.
- d) Analysis sequence/run chronology.
- e) Sample weight or volume (Section 11).
- f) Extract volume prior to each cleanup step (Section 13).
- g) Extract volume after each cleanup step (Section 13).
- h) Final extract volume prior to injection (Section 14).
- i) Injection volume (Section 14.3).
- j) Dilution data, differentiating between dilution of a sample or extract (Section 17.5).

- k) Instrument and operating conditions.
- l) Column (dimensions, liquid phase, solid support, film thickness, etc).
- m) Operating conditions (temperatures, temperature program, flow rates).
- n) Detector (type, operating conditions, etc).
- o) Chromatograms, printer tapes, and other recordings of raw data.
- p) Quantitation reports, data system outputs, and other data to link the raw data to the results reported.

9.1.2.3 Alternate HRGC columns and column systems—See Sections 6.9.1. If a column or column system alternate to those specified in this Method is used, that column or column system must meet the requirements in Section 6.9.1 - 6.9.1.1.3.

9.1.3 Analyses of method blanks are required to demonstrate freedom from contamination (Section 4.3). The procedures and criteria for analysis of a method blank are described in Sections 9.5 and 15.6.

9.1.4 The laboratory must spike all samples with labeled compounds to monitor Method performance. This test is described in Section 9.3. When results of these spikes indicate atypical Method performance for samples, the samples are diluted to bring Method performance within acceptable limits. Procedures for dilution are given in Section 17.5.

9.1.5 The laboratory must, on an ongoing basis, demonstrate through calibration verification and the analysis of the ongoing precision and recovery standard (OPR) and blanks that the analytical system is in control. These procedures are given in Sections 15.1 through 15.6.

9.1.6 The laboratory should maintain records to define the quality of data generated. Development of accuracy statements is described in Section 9.4.

9.2 Initial precision and recovery (IPR)—To establish the ability to generate acceptable precision and recovery, the laboratory must perform the following operations.

9.2.1 For low solids (aqueous) samples, extract, concentrate, and analyze four 1-L aliquots of reagent water spiked with 1 mL each of the Native Toxics/LOC spiking solution (Section 7.11), the Labeled Toxics/LOC/window-defining standard spiking solution (Section 7.12), and the Labeled cleanup standard spiking solution (Section 7.13), according to the procedures in Sections 11 through 18. For an alternative sample matrix, four aliquots of the alternative reference matrix (Section 7.6) are used. All sample processing steps that are to

be used for processing samples, including preparation (Section 11), extraction (Section 12), and cleanup (Section 13), must be included in this test.

- 9.2.2** Using results of the set of four analyses, compute the average percent recovery (X) of the extracts and the relative standard deviation (RSD) of the concentration for each compound, by isotope dilution for CBs with a labeled analog, and by internal standard for CBs without a labeled analog and for the labeled compounds.
 - 9.2.3** For each CB and labeled compound, compare RSD and X with the corresponding limits for initial precision and recovery in Table 6. If RSD and X for all compounds meet the acceptance criteria, system performance is acceptable and analysis of blanks and samples may begin. If, however, any individual RSD exceeds the precision limit or any individual X falls outside the range for recovery, system performance is unacceptable for that compound. Correct the problem and repeat the test (Section 9.2).
- 9.3** To assess Method performance on the sample matrix, the laboratory must spike all samples with the Labeled Toxics/LOC/window-defining standard spiking solution (Section 7.12) and all sample extracts with the Labeled cleanup standard spiking solution (Section 7.13).
- 9.3.1** Analyze each sample according to the procedures in Sections 11 through 18.
 - 9.3.2** Compute the percent recovery of the labeled Toxics/LOC/window-defining congeners and the labeled cleanup congeners using the internal standard method (Section 17.2).
 - 9.3.3** The recovery of each labeled compound must be within the limits in Table 6. If the recovery of any compound falls outside of these limits, Method performance is unacceptable for that compound in that sample. Additional cleanup procedures must then be employed to attempt to bring the recovery within the normal range. If the recovery cannot be brought within the normal range after all cleanup procedures have been employed, water samples are diluted and smaller amounts of soils, sludges, sediments, and other matrices are analyzed per Section 18.
- 9.4** It is suggested but not required that recovery of labeled compounds from samples be assessed and records maintained.
- 9.4.1** After the analysis of 30 samples of a given matrix type (water, soil, sludge, pulp, etc.) for which the labeled compounds pass the tests in Section 9.3, compute the average percent recovery (R) and the standard deviation of the percent recovery (S_R) for the labeled compounds only. Express the assessment as a percent recovery interval from $R - 2S_R$ to $R + 2S_R$ for each matrix. For example, if $R =$

90% and $S_R = 10\%$ for five analyses of pulp, the recovery interval is expressed as 70 to 110%.

- 9.4.2** Update the accuracy assessment for each labeled compound in each matrix on a regular basis (e.g., after each five to ten new measurements).
- 9.5** Method blanks—A reference matrix Method blank is analyzed with each sample batch (Section 4.3) to demonstrate freedom from contamination. The matrix for the Method blank must be similar to the sample matrix for the batch, e.g., a 1-L reagent water blank (Section 7.6.1), high-solids reference matrix blank (Section 7.6.2), paper matrix blank (Section 7.6.3); tissue blank (Section 7.6.4), or alternative reference matrix blank (Section 7.6.5).
- 9.5.1** Spike 1.0 mL each of the Labeled Toxics/LOC/window-defining standard spiking solution (Section 7.12), and the Labeled cleanup standard spiking solution (Section 7.13) into the Method blank, according to the procedures in Sections 11 through 18. Prepare, extract, clean up, and concentrate the Method blank. Analyze the blank immediately after analysis of the OPR (Section 15.5) to demonstrate freedom from contamination.
- 9.5.2** If any CB (Table 1) is found in the blank at greater than the minimum level (Table 2) or one-third the regulatory compliance limit, whichever is greater; or if any potentially interfering compound is found in the blank at the minimum level for each CB given in Table 2 (assuming a response factor of 1 relative to the quantitation reference in Table 2 at that level of chlorination for a potentially interfering compound; i.e., a compound not listed in this Method), analysis of samples must be halted until the sample batch is re-extracted and the extracts re-analyzed, and the blank associated with the sample batch shows no evidence of contamination at these levels. All samples must be associated with an uncontaminated Method blank before the results for those samples may be reported or used for permitting or regulatory compliance purposes.
- 9.6** QC Check Sample—Analyze the QC Check Sample (Section 7.15) periodically to assure the accuracy of calibration standards and the overall reliability of the analytical process. It is suggested that the QC Check Sample be analyzed at least quarterly.
- 9.7** The specifications contained in this Method can be met if the apparatus used is calibrated properly and then maintained in a calibrated state. The standards used for calibration (Section 10), calibration verification (Section 15.3), and for initial (Section 9.2) and ongoing (Section 15.5) precision and recovery should be identical, so that the most precise results will be obtained. A GC/MS instrument will provide the most reproducible results if dedicated to the settings and conditions required for determination of CBs by this Method.

- 9.8** Depending on specific program requirements, field replicates may be collected to determine the precision of the sampling technique, and spiked samples may be required to determine the accuracy of the analysis when the internal standard method is used.

10.0 Calibration

- 10.1** Establish the operating conditions necessary to meet the retention times (RTs) and relative retention times (RRTs) for the CBs in Table 2.

10.1.1 Suggested GC operating conditions:

Injector temperature:	270 °C
Interface temperature:	290 °C
Initial temperature:	75 °C
Initial time:	2 minutes
Temperature program:	75-150 °C @ 15 °C/minute 150-290 °C @ 2.5 °C/minute
Final time:	1 minute

Note: *All portions of the column that connect the GC to the ion source should remain at or above the interface temperature specified above during analysis to preclude condensation of less volatile compounds.*

The GC conditions may be optimized for compound separation and sensitivity. Once optimized, the same GC conditions must be used for the analysis of all standards, blanks, IPR and OPR standards, and samples.

10.1.2 Retention time calibration for the CB congeners

- 10.1.2.1** Separately inject each of the diluted individual congener solutions (Section 7.10.2.1.2). Establish the beginning and ending retention times for the scan descriptors in Table 7. Scan descriptors other than those listed in Table 7 may be used provided the MLs in Table 2 are met. Store the retention time (RT) and relative retention time (RRT) for each congener in the data system.
- 10.1.2.2** The absolute retention time of CB 209 must exceed 55 minutes on the SPB-octyl column; otherwise, the GC temperature program must be adjusted and this test repeated until the minimum retention time criterion is met. If a GC column or column system alternate to the SPB-octyl column is used, a similar minimum retention time specification must be established for the alternate column or column systems so that interferences that may be encountered in environmental samples will be resolved from the analytes of interest.

This specification is deemed to be met if the retention time of CB 209 is greater than 55 minutes on such alternate column.

10.1.2.3 Inject the Diluted combined 209 congener solution (Section 7.10.2.2 and Table 5). Adjust the chromatographic conditions and scan descriptors until the RT and RRT for all congeners are within the windows in Table 2 and the column performance specifications in Sections 6.9.1 - 6.9.1.2 are met. If an alternate column is used, adjust the conditions for that column. If column performance is unacceptable, optimize the analysis conditions or replace the column and repeat the performance tests. Confirm that the scan descriptor changes at times when CBs do not elute.

10.1.2.4 After the column performance tests are passed (Section 10.1.2.2 - 10.1.2.3), store the RT and RRT for the resolved congeners and the RT and RRT for the isomeric congeners that co-elute.

10.2 Mass spectrometer (MS) resolution

10.2.1 Using PFK (or other reference substance) and a molecular leak, tune the instrument to meet the minimum required resolving power of 10,000 (10% valley) at m/z 330.9792 or any other significant PFK fragment in the range of 300 to 350. For each descriptor (Table 7), monitor and record the resolution and exact m/z 's of three to five reference peaks covering the mass range of the descriptor. The level of PFK (or other reference substance) metered into the HRMS during analyses should be adjusted so that the amplitude of the most intense selected lock-mass m/z signal (regardless of the descriptor number) does not exceed 10% of the full-scale deflection for a given set of detector parameters. Under those conditions, sensitivity changes that might occur during the analysis can be more effectively monitored.

Note: *Different lots and types of PFK can contain varying levels of contamination, and excessive PFK (or other reference substance) may cause noise problems and contamination of the ion source necessitating increased frequency of source cleaning.*

10.2.2 The analysis time for CBs may exceed the long-term mass stability of the mass spectrometer. Because the instrument is operated in the high-resolution mode, mass drifts of a few ppm (e.g., 5 ppm in mass) can have serious adverse effects on instrument performance. Therefore, mass-drift correction is mandatory and a lock-mass m/z from perfluorokerosene (PFK) or other reference substance is used for drift correction. The lock-mass m/z is dependent on the exact m/z 's monitored within each descriptor, as shown in Table 7. The deviation between the exact m/z and the theoretical m/z (Table 7) for each exact m/z monitored must be less than 5 ppm.

- 10.2.3** Obtain a selected ion current profile (SICP) at the two exact m/z's specified in Table 7 and at $\geq 10,000$ resolving power at each LOC for the native congeners and congener groups and for the labeled congeners. Because of the extensive mass range covered in each function, it may not be possible to maintain 10,000 resolution throughout the mass range during the function. Therefore, resolution must be $\geq 8,000$ throughout the mass range and must be $\geq 10,000$ in the center of the mass range for each function.
- 10.2.4** If the HRMS has the capability to monitor resolution during the analysis, it is acceptable to terminate the analysis when the resolution falls below the minimum (Section 10.2.1.3) to save re-analysis time.
- 10.3** Ion abundance ratios, minimum levels, and signal-to-noise ratios. Choose an injection volume of either 1 or 2 μL , consistent with the capability of the HRGC/HRMS instrument. Inject a 1 or 2 μL aliquot of the CS-1 calibration solution (Table 5) using the GC conditions in Section 10.1.1.
- 10.3.1** Measure the SICP areas for each congener or congener group, and compute the ion abundance ratios at the exact m/z's specified in Table 7. Compare the computed ratio to the theoretical ratio given in Table 8.
- 10.3.1.1** The exact m/z's to be monitored in each descriptor are shown in Table 7. Each group or descriptor must be monitored in succession as a function of GC retention time to ensure that the CBs of interest are detected. Additional m/z's may be monitored in each descriptor, and the m/z's may be divided among more than the descriptors listed in Table 7, provided that the laboratory is able to monitor the m/z's of all CBs that may elute from the GC in a given LOC window. The laboratory must also monitor exact m/z's for congeners at higher levels of chlorination to determine if fragments will compromise measurement of congeners at lower levels of chlorination.
- 10.3.1.2** The mass spectrometer must be operated in a mass-drift correction mode, using PFK (or other reference substance) to provide lock m/z's. The lock mass for each group of m/z's is shown in Table 7. Each lock mass must be monitored and must not vary by more than $\pm 20\%$ throughout its respective retention time window. Variations of lock mass by more than 20% indicate the presence of co-eluting interferences that raise the source pressure and may significantly reduce the sensitivity of the mass spectrometer. Re-injection of another aliquot of the sample extract may not resolve the problem and additional cleanup of the extract may be required to remove the interference. A lock mass interference or suppression in a retention time region in which CBs and labeled compounds do not elute may be ignored.

10.3.2 All CBs and labeled compounds in the CS-1 standard must be within the QC limits in Table 8 for their respective ion abundance ratios; otherwise, the mass spectrometer must be adjusted and this test repeated until the m/z ratios fall within the limits specified. If the adjustment alters the resolution of the mass spectrometer, resolution must be verified (Section 10.2.1) prior to repeat of the test.

10.3.3 Verify that the HRGC/HRMS instrument meets the estimated minimum levels (EMLs) in Table 2. The peaks representing the CBs and labeled compounds in the CS-1 calibration standard must have signal-to-noise ratios (S/N) ≥ 10 ; otherwise, the mass spectrometer must be adjusted and this test repeated until the minimum levels in Table 2 are met.

Note: *The EMDLs and EMLs in Table 2 are based on the levels of contamination normally found in laboratories. Lower levels may be readily achievable if segregation and extensive cleaning of glassware is employed. If lower levels are achievable, these levels must be established as described in Section 17.6.1.4.1.*

10.4 Calibration by isotope dilution—Isotope dilution is used for calibration of the Toxics/LOC CBs. The reference compound for each native compound its labeled analog, as listed in Table 2. A 5- or 6-point calibration encompassing the concentration range is prepared for each native congener.

10.4.1 For the Toxics/LOC CBs determined by isotope dilution, the relative response (RR) (labeled to native) vs. concentration in the calibration solutions (Table 5) is computed over the calibration range according to the procedures described below. Five calibration points are employed for less-sensitive HRMS instruments (e.g., VG 70); five or six points may be employed for more-sensitive instruments (e.g., Micromass Autospec Ultima).

10.4.2 The response of each Toxics/LOC CB relative to its labeled analog is determined using the area responses of both the primary and secondary exact m/z's specified in Table 7, for each calibration standard, as follows:

$$RR = \frac{(AI_n + A2_n) C_l}{(AI_l + A2_l) C_n}$$

Where:

AI_n and $A2_n$ = The areas of the primary and secondary m/z's for the PCB.

AI_l and $A2_l$ = The areas of the primary and secondary m/z's for the labeled compound.

C_l = The concentration of the labeled compound in the calibration standard (Table 5).

C_n = The concentration of the native compound in the calibration standard (Table 5).

10.4.3 To calibrate the analytical system by isotope dilution, inject calibration standards CS-1 through CS-5 (Section 7.10 and Table 5) for a less sensitive instrument or CS-0.2 through CS-5 for a more sensitive instrument. Use a volume identical to the volume chosen in Section 10.3, the procedure in Section 14, and the conditions in Section 10.1.1. Compute and store the relative response (RR) for each Native Toxics/LOC CB at each concentration. Compute the average (mean) RR and the RSD of the 5 (or 6) RRs.

10.4.4 Linearity—If the RR for any Native Toxics/LOC CB is constant (less than 20% RSD), the average RR may be used for that congener; otherwise, the complete calibration curve for that congener must be used over the calibration range.

10.5 Calibration by internal standard—Internal standard calibration is applied to determination of the native CBs for which a labeled compound is not available, to determination of the Labeled Toxics/LOC/window-defining congeners and Labeled cleanup congeners for performance tests and intra-laboratory statistics (Sections 9.4 and 15.5.4), and to determination of the Labeled injection internal standards except for CB 178. The reference compound for each compound is listed in Table 2. For the native congeners (other than the Native Toxics/LOC CBs), calibration is performed at a single point using the CS-3 (VER) standard. For the labeled compounds, calibration is performed using data from the 5 (or 6) points in the calibration for the Native Toxics/LOC CBs (Section 10.4).

10.5.1 Response factors—Internal standard calibration requires the determination of response factors (RF) defined by the following equation:

$$RF = \frac{(AI_s + A2_s) C_{is}}{(AI_{is} + A2_{is}) C_s}$$

Where:

AI_s and $A2_s$ = The areas of the primary and secondary m/z's for the PCB.

AI_{is} and $A2_{is}$ = The areas of the primary and secondary m/z's for the internal standard.

C_{is} = The concentration of the internal standard (Table 5).

C_s = The concentration of the compound in the calibration standard (Table 5).

10.5.2 To single-concentration calibrate the analytical system for native CBs other than the Native Toxics/LOC CBs by internal standard, inject the Diluted combined 209 congener solution (Section 7.10.2.2 and Table 3). Use a volume identical to the volume chosen in Section 10.3, the procedure in Section 14, and the conditions in Section 10.1.1.

10.5.3 Compute and store the response factor (RF) for all native CBs except the Native Toxics/LOC CBs. Use the average (mean) response of the labeled compounds at each level of chlorination (LOC) as the quantitation reference, as shown in Table 2. For the combinations of isomeric congeners that co-elute, compute a

combined RF for the co-eluted group. For example, for congener 122, the areas at the two exact m/z's for 104L, 105L, 114L, 123L, 118L, and 126L are summed and the total area is divided by 6 (because there are 6 congeners in the quantitation reference).

Note: *All labeled congeners at each LOC are used as reference to reduce the effect of an interference if a single congener is used as reference. Other quantitation references and procedures may be used provided that the results produced are as accurate as results produced by the quantitation references and procedures described in this Section.*

- 10.5.4** Compute and store the response factor (RF) for the labeled compounds, except CB 178. For the Labeled Toxics/LOC/window-defining compounds and the Labeled cleanup standards, use the nearest eluted Labeled injection internal standard as the quantitation reference, as given in Table 2. The Labeled injection internal standards are referenced to CB 178, as shown in Table 2.

11.0 Sample preparation

- 11.1** Sample preparation involves modifying the physical form of the sample so that the CBs can be extracted efficiently. In general, the samples must be in a liquid form or in the form of finely divided solids in order for efficient extraction to take place. Table 9 lists the phases and suggested quantities for extraction of various sample matrices.

For samples known or expected to contain high levels of the CBs, the smallest sample size representative of the entire sample should be used (see Section 18). For all samples, the blank and IPR/OPR aliquots must be processed through the same steps as the sample to check for contamination and losses in the preparation processes.

- 11.1.1** For samples that contain particles, percent solids and particle size are determined using the procedures in Sections 11.2 and 11.3, respectively.
- 11.1.2** Aqueous samples—Because CBs may be bound to suspended particles, the preparation of aqueous samples is dependent on the solids content of the sample.
- 11.1.2.1** Aqueous samples containing one percent solids or less are prepared per Section 11.4 and extracted directly using one of the extraction techniques in Section 12.2.
- 11.1.2.2** For aqueous samples containing greater than one percent solids, a sample aliquot sufficient to provide 10 g of dry solids is used, as described in Section 11.5.
- 11.1.3** Solid samples are prepared using the procedure described in Section 11.5 followed by extraction using the SDS procedure in Section 12.3.

11.1.4 Multi-phase samples—The phase(s) containing the CBs is separated from the non-CB phase using pressure filtration and centrifugation, as described in Section 11.6. The CBs will be in the organic phase in a multi-phase sample in which an organic phase exists.

11.1.5 Procedures for grinding, homogenization, and blending of various sample phases are given in Section 11.7.

11.1.6 Tissue samples—Preparation procedures for fish and other tissues are given in Section 11.8.

11.2 Determination of percent suspended solids.

Note: *This aliquot is used for determining the solids content of the sample, not for determination of CBs.*

11.2.1 Aqueous liquids and multi-phase samples consisting of mainly an aqueous phase.

11.2.1.1 Desiccate and weigh a GF/D filter (Section 6.5.3) to three significant figures.

11.2.1.2 Filter 10.0 ± 0.02 mL of well-mixed sample through the filter.

11.2.1.3 Dry the filter a minimum of 12 hours at 110 ± 5 °C and cool in a desiccator.

11.2.1.4 Calculate percent solids as follows:

$$\% \text{ solids} = \frac{\text{weight of sample aliquot after drying (g)} - \text{weight of filter (g)}}{10 \text{ g}} \times 100$$

11.2.2 Non-aqueous liquids, solids, semi-solid samples, and multi-phase samples in which the main phase is not aqueous; but not tissues.

11.2.2.1 Weigh 5 to 10 g of sample to three significant figures in a tared beaker.

11.2.2.2 Dry a minimum of 12 hours at 110 ± 5 °C, and cool in a desiccator.

11.2.2.3 Calculate percent solids as follows:

$$\% \text{ solids} = \frac{\text{weight of sample aliquot after drying}}{\text{weight of sample aliquot before drying}} \times 100$$

11.3 Estimation of particle size.

11.3.1 Spread the dried sample from Section 11.2.2.2 on a piece of filter paper or aluminum foil in a fume hood or glove box.

11.3.2 Estimate the size of the particles in the sample. If the size of the largest particles is greater than 1 mm, the particle size must be reduced to 1 mm or less prior to extraction using the procedures in Section 11.7.

11.4 Preparation of aqueous samples containing one percent suspended solids or less.

11.4.1 Aqueous samples containing one percent suspended solids or less are prepared using the procedure below and extracted using the one of the extraction techniques in Section 12.2.

11.4.2 Preparation of sample and QC aliquots.

11.4.2.1 Mark the original level of the sample on the sample bottle for reference. Weigh the sample plus bottle to ± 1 g.

11.4.2.2 Spike 1.0 mL of the Labeled Toxics/LOC/window-defining standard spiking solution (Section 7.12) into the sample bottle. Cap the bottle and mix the sample by careful shaking. Allow the sample to equilibrate for 1 to 2 hours, with occasional shaking.

11.4.2.3 For each sample or sample batch (to a maximum of 20 samples) to be extracted during the same 12-hour shift, place two 1.0-L aliquots of reagent water in clean sample bottles or flasks.

11.4.2.4 Spike 1.0 mL of the Labeled Toxics/LOC/window-defining standard spiking solution (Section 7.12) into both reagent water aliquots. One of these aliquots will serve as the Method blank.

11.4.2.5 Spike 1.0 mL of the Native Toxics/LOC standard spiking solution (Section 7.11) into the remaining reagent water aliquot. This aliquot will serve as the OPR (Section 15.5).

11.4.2.6 For extraction using SPE, add 5 mL of methanol to the sample and QC aliquots. Cap and shake the sample and QC aliquots to mix thoroughly, and proceed to Section 12.2 for extraction.

11.5 Preparation of samples containing greater than one percent solids.

- 11.5.1** Weigh a well-mixed aliquot of each sample (of the same matrix type) sufficient to provide 10 g of dry solids (based on the solids determination in Section 11.2) into a clean beaker or glass jar.
 - 11.5.2** Spike 1.0 mL of the Labeled Toxics/LOC/window-defining standard spiking solution (Section 7.12) into the sample.
 - 11.5.3** For each sample or sample batch (to a maximum of 20 samples) to be extracted during the same 12 hour shift, weigh two 10-g aliquots of the appropriate reference matrix (Section 7.6) into clean beakers or glass jars.
 - 11.5.4** Spike 1.0 mL of the Labeled Toxics/LOC/window-defining standard spiking solution (Section 7.12) into both reference matrix aliquots. Spike 1.0 mL of the Native Toxics/LOC standard spiking solution (Section 7.11) into one reference matrix aliquot. This aliquot will serve as the OPR (Section 15.5). The other aliquot will serve as the Method blank.
 - 11.5.5** Stir or tumble and equilibrate the aliquots for 1 to 2 hours.
 - 11.5.6** Decant excess water. If necessary to remove water, filter the sample through a glass-fiber filter and discard the aqueous liquid.
 - 11.5.7** If particles >1 mm are present in the sample (as determined in Section 11.3.2), spread the sample on clean aluminum foil in a hood. After the sample is dry, grind to reduce the particle size (Section 11.7).
 - 11.5.8** Extract the sample and QC aliquots using the SDS procedure in Section 12.3.
- 11.6** Multi-phase samples.
- 11.6.1** Using the percent solids determined in Section 11.2.1 or 11.2.2, determine the volume of sample that will provide 10 g of solids, up to 1 L of sample.
 - 11.6.2** Spike 1.0 mL of the Labeled Toxics/LOC/window-defining standard spiking solution (Section 7.12) into the amount of sample determined in Section 11.6.1, and into the OPR and blank. Spike 1.0 mL of the Native Toxics/LOC standard spiking solution (Section 7.11) into the OPR. Pressure filter the sample, blank, and OPR through Whatman GF/D glass-fiber filter paper (Section 6.5.3). If necessary to separate the phases and/or settle the solids, centrifuge these aliquots prior to filtration.
 - 11.6.3** Discard any aqueous phase (if present). Remove any non-aqueous liquid present and reserve the maximum amount filtered from the sample (Section 11.6.1) or 10 g, whichever is less, for combination with the solid phase (Section 12.3.5).

- 11.6.4** If particles >1 mm are present in the sample (as determined in Section 11.3.2) and the sample is capable of being dried, spread the sample and QC aliquots on clean aluminum foil in a hood. Observe the precaution in Section 4.8.
- 11.6.5** After the aliquots are dry or if the sample cannot be dried, reduce the particle size using the procedures in Section 11.7 and extract the reduced-size particles using the SDS procedure in Section 12.3. If particles >1 mm are not present, extract the particles and filter in the sample and QC aliquots directly using the SDS procedure in Section 12.3.
- 11.7** Sample grinding, homogenization, or blending—Samples with particle sizes greater than 1 mm (as determined in Section 11.3.2) are subjected to grinding, homogenization, or blending. The method of reducing particle size to less than 1 mm is matrix-dependent. In general, hard particles can be reduced by grinding with a mortar and pestle. Softer particles can be reduced by grinding in a Wiley mill or meat grinder, by homogenization, or in a blender.
- 11.7.1** Each size-reducing preparation procedure on each matrix must be verified by running the tests in Section 9.2 before the procedure is employed routinely.
- 11.7.2** The grinding, homogenization, or blending procedures must be carried out in a glove box or fume hood to prevent particles from contaminating the work environment.
- 11.7.3** Grinding—Certain papers and pulps, slurries, and amorphous solids can be ground in a Wiley mill or heavy duty meat grinder. In some cases, reducing the temperature of the sample to freezing or to dry ice or liquid nitrogen temperatures can aid in the grinding process. Grind the sample aliquots from Sections 11.5.7 or 11.6.5 in a clean grinder. Do not allow the sample temperature to exceed 50 °C. Grind the blank and reference matrix aliquots using a clean grinder.
- 11.7.4** Homogenization or blending—Particles that are not ground effectively, or particles greater than 1 mm in size after grinding, can often be reduced in size by high speed homogenization or blending. Homogenize and/or blend the particles or filter from Sections 11.5.7 or 11.6.5 for the sample, blank, and OPR aliquots.
- 11.7.5** Extract the aliquots using the SDS procedure in Section 12.3.
- 11.8** Fish and other tissues—Prior to processing tissue samples, the laboratory must determine the exact tissue to be analyzed. Common requests for analysis of fish tissue include whole fish-skin on, whole fish-skin removed, edible fish fillets (filleted in the field or by the laboratory), specific organs, and other portions. Once the appropriate tissue has been determined, the sample must be homogenized.

11.8.1 Homogenization

- 11.8.1.1 Samples are homogenized while still frozen, where practical. If the laboratory must dissect the whole fish to obtain the appropriate tissue for analysis, the unused tissues may be rapidly refrozen and stored in a clean glass jar for subsequent use.
- 11.8.1.2 Each analysis requires 10 g of tissue (wet weight). Therefore, the laboratory should homogenize at least 20 g of tissue to allow for re-extraction of a second aliquot of the same homogenized sample, if re-analysis is required. When whole fish analysis is necessary, the entire fish is homogenized.
- 11.8.1.3 Homogenize the sample in a tissue homogenizer (Section 6.3.3) or grind in a meat grinder (Section 6.3.4). Cut tissue too large to feed into the grinder into smaller pieces. To assure homogeneity, grind three times.
- 11.8.1.4 Transfer approximately 10 g (wet weight) of homogenized tissue to a clean, tared, 400- to 500-mL beaker.
- 11.8.1.5 Transfer the remaining homogenized tissue to a clean jar with a fluoropolymer-lined lid. Seal the jar and store the tissue at <-10 °C. Return any tissue that was not homogenized to its original container and store at <-10 °C.

11.8.2 QC aliquots

- 11.8.2.1 Prepare a Method blank by adding approximately 1-2 g of the oily liquid reference matrix (Section 7.6.4) to a 400- to 500-mL beaker.
- 11.8.2.2 Prepare a precision and recovery aliquot by adding 1-2 g of the oily liquid reference matrix (Section 7.6.4) to a separate 400- to 500-mL beaker. Record the weight to the nearest 10 mg. If the initial precision and recovery test is to be performed, use four aliquots; if the ongoing precision and recovery test is to be performed, use a single aliquot.

11.8.3 Spiking

- 11.8.3.1 Spike 1.0 mL of the Labeled Toxics/LOC/window-defining standard spiking solution (Section 7.12) into the sample, blank, and OPR aliquot.

11.8.3.2 Spike 1.0 mL of the Native Toxics/LOC standard spiking solution (Section 7.11) into the OPR aliquot.

11.8.4 Extract the aliquots using the procedures in Section 12.4.

12.0 Extraction and concentration

12.1 Extraction procedures include solid phase (Section 12.2.1), separatory funnel (Section 12.2.2), and continuous liquid/liquid (Section 12.2.3) for aqueous liquids; Soxhlet/Dean-Stark (Section 12.3) for solids and filters; and Soxhlet extraction (Section 12.4) for tissues. Acid/base back-extraction (Section 12.5) is used for initial cleanup of extracts.

Macro-concentration procedures include rotary evaporation (Section 12.6.1), heating mantle (Section 12.6.2), and Kuderna-Danish (K-D) evaporation (Section 12.6.3). Micro-concentration uses nitrogen blowdown (Section 12.7).

12.2 Extraction of aqueous liquids

12.2.1 SPE of samples containing less than one percent solids.

12.2.1.1 Disk preparation

12.2.1.1.1 Remove the test tube from the suction flask (Figure 4). Place an SPE disk on the base of the filter holder and wet with methylene chloride. While holding a GMF 150 filter above the SPE disk with tweezers, wet the filter with methylene chloride and lay the filter on the SPE disk, making sure that air is not trapped between the filter and disk. Clamp the filter and SPE disk between the 1-L glass reservoir and the vacuum filtration flask.

12.2.1.1.2 Rinse the sides of the reservoir with approx 15 mL of methylene chloride using a squeeze bottle or pipet. Apply vacuum momentarily until a few drops appear at the drip tip. Release the vacuum and allow the filter/disk to soak for approx one minute. Apply vacuum and draw all of the methylene chloride through the filter/disk. Repeat the wash step with approx 15 mL of acetone and allow the filter/disk to air dry.

12.2.1.2 Sample extraction.

12.2.1.2.1 Pre-wet the disk by adding approx 20 mL of methanol to the reservoir. Pull most of the methanol through the filter/disk, retaining a layer of methanol approx 2 mm

thick on the filter. Do not allow the filter/disk to go dry from this point until the extraction is completed.

12.2.1.2.2 Add approx 20 mL of reagent water to the reservoir and pull most through, leaving a layer approx 2 mm thick on the filter/disk.

12.2.1.2.3 Allow the sample (Section 11.4.2.6) to stand for 1-2 hours, if necessary, to settle the suspended particles. Decant the clear layer of the sample, the blank (Section 11.4.2.4), or IPR/OPR aliquot (Section 11.4.2.5) into its respective reservoir and turn on the vacuum to begin the extraction. Adjust the vacuum to complete the extraction in no less than 10 minutes. For samples containing a high concentration of particles (suspended solids), the extraction time may be an hour or longer.

12.2.1.2.4 Before all of the sample has been pulled through the filter/disk, add approx 50 mL of reagent water to the sample bottle, swirl to suspend the solids (if present), and pour into the reservoir. Pull through the filter/disk. Use additional reagent water rinses until all solids are removed.

12.2.1.2.5 Before all of the sample and rinses have been pulled through the filter/disk, rinse the sides of the reservoir with small portions of reagent water.

12.2.1.2.6 Partially dry the filter/disk under vacuum for approx 3 minutes.

12.2.1.3 Elution of the filter/disk.

12.2.1.3.1 Release the vacuum, remove the entire filter/disk/reservoir assembly from the vacuum flask, and empty the flask. Insert a test tube for eluant collection into the flask. The test tube should have sufficient capacity to contain the total volume of the elution solvent (approx 50 mL) and should fit around the drip tip. The drip tip should protrude into the test tube to preclude loss of sample from spattering when vacuum is applied. Reassemble the filter/disk/reservoir assembly on the vacuum flask.

12.2.1.3.2 Wet the filter/disk with 4-5 mL of acetone. Allow the acetone to spread evenly across the disk and soak for 15-20 seconds. Pull the acetone through the disk, releasing the vacuum when approx 1 mm thickness remains on the filter.

12.2.1.3.3 Rinse the sample bottle with approx 20 mL of methylene chloride and transfer to the reservoir. Pull approx half of the solvent through the filter/disk and release the vacuum. Allow the filter/disk to soak for approx 1 minute. Pull all of the solvent through the disk. Repeat the bottle rinsing and elution step with another 20 mL of methylene chloride. Pull all of the solvent through the disk.

12.2.1.3.4 Release the vacuum, remove the filter/disk/reservoir assembly, and remove the test tube containing the sample solution. Quantitatively transfer the solution to a 250-mL separatory funnel and proceed to Section 12.5 for back-extraction.

12.2.2 Separatory funnel extraction

12.2.2.1 Pour the spiked sample (Section 11.4.2.2) into a 2-L separatory funnel. Rinse the bottle or flask twice with 5 mL of reagent water and add these rinses to the separatory funnel.

12.2.2.2 Add 60 mL methylene chloride to the empty sample bottle. Seal the bottle and shake 60 seconds to rinse the inner surface. Transfer the solvent to the separatory funnel, and extract the sample by shaking the funnel for 2 minutes with periodic venting. Allow the organic layer to separate from the aqueous phase for a minimum of 10 minutes. If an emulsion forms and is more than one-third the volume of the solvent layer, employ mechanical techniques to complete the phase separation (see note below). Drain the methylene chloride extract through a solvent-rinsed glass funnel approximately one-half full of granular anhydrous sodium sulfate (Section 7.2.1) supported on clean glass-fiber paper into a solvent-rinsed concentration device (Section 12.6).

Note: *If an emulsion forms, the laboratory must employ mechanical techniques to complete the phase separation. The optimum technique depends upon the sample, but may include stirring, filtration through glass wool, use of phase separation paper, centrifugation, use of an ultrasonic bath with ice, addition of NaCl, or other physical methods. Alternatively, solid-phase (Section 12.2.1), CLLE (Section 12.2.3), or other extraction techniques may be used to prevent emulsion formation. Any alternative technique is acceptable so long as the requirements in Section 9.2 are met.*

12.2.2.3 Extract the water sample two more times with 60-mL portions of methylene chloride. Drain each portion through the sodium sulfate into the concentrator. After the third extraction, rinse the separatory funnel with at least 20 mL of methylene chloride, and drain this rinse through the sodium sulfate into the concentrator. Repeat this rinse at least twice. Set aside the funnel with sodium sulfate if the extract is to be combined with the extract from the particles.

12.2.2.4 Concentrate the extract using one of the macro-concentration procedures in Section 12.6 and proceed to back extraction in Section 12.5.

12.2.3 Continuous liquid/liquid extraction

12.2.3.1 Place 100-150 mL methylene chloride in each continuous extractor and 200-300 mL in each distilling flask.

12.2.3.2 Pour the sample(s), blank, and QC aliquots into the extractors. Rinse the sample containers with 50-100 mL methylene chloride and add to the respective extractors. Include all solids in the extraction process.

12.2.3.3 Begin the extraction by heating the flask until the methylene chloride is boiling. When properly adjusted, 1-2 drops of methylene chloride per second will fall from the condenser tip into the water. Extract for 16-24 hours.

12.2.3.4 Remove the distilling flask, estimate and record the volume of extract (to the nearest 100 mL), and pour the contents through a drying column containing 7 to 10 cm of granular anhydrous sodium sulfate into a 500-mL K-D evaporator flask equipped with a 10-mL concentrator tube. Rinse the distilling flask with 30-50 mL of methylene chloride and pour through the drying column. Concentrate and exchange to hexane per Section 12.6 and back extract per Section 12.5.

12.3 SDS extraction of samples containing particles.

12.3.1 Charge a clean extraction thimble (Section 6.4.2.2) with 5.0 g of 100/200 mesh silica (Section 7.5.1.1) topped with 100 g of quartz sand (Section 7.3.2).

Note: *Do not disturb the silica layer throughout the extraction process.*

12.3.2 Place the thimble in a clean extractor. Place 30 to 40 mL of toluene in the receiver and 200 to 250 mL of toluene in the flask.

12.3.3 Pre-extract the glassware by heating the flask until the toluene is boiling. When properly adjusted, 1 to 2 drops of toluene will fall per second from the condenser tip into the receiver. Extract the apparatus for a minimum of 3 hours.

12.3.4 After pre-extraction, cool and disassemble the apparatus. Rinse the thimble with toluene and allow to air dry.

12.3.5 Load the wet sample and/or filter from Sections 11.5.8, 11.6.5, or 11.7.5 and any nonaqueous liquid from Section 11.6.3 into the thimble and manually mix into the sand layer with a clean metal spatula, carefully breaking up any large lumps of sample.

12.3.6 Reassemble the pre-extracted SDS apparatus, and add a fresh charge of toluene to the receiver and reflux flask. Apply power to the heating mantle to begin refluxing. Adjust the reflux rate to match the rate of percolation through the sand and silica beds until water removal lessens the restriction to toluene flow. Frequently check the apparatus for foaming during the first 2 hours of extraction. If foaming occurs, reduce the reflux rate until foaming subsides.

12.3.7 Drain the water from the receiver at 1-2 hours and 8-9 hours, or sooner if the receiver fills with water. Reflux the sample for a total of 16-24 hours. Cool and disassemble the apparatus. Record the total volume of water collected.

12.3.8 Remove the distilling flask. Drain the water from the Dean-Stark receiver and add any toluene in the receiver to the extract in the flask.

12.3.9 Concentrate the extracts from particles to approximately 10 mL using the rotary evaporator (Section 12.6.1) or heating mantle (Section 12.6.2), transfer to a 250-mL separatory funnel, and proceed with back-extraction (Section 12.5).

12.4 Soxhlet extraction of tissue

12.4.1 Add 30 to 40 g of powdered anhydrous sodium sulfate (Section 7.2.2) to each of the beakers (Section 11.8.4) and mix thoroughly. Cover the beakers with

aluminum foil and allow to equilibrate for 12-24 hours. Remix prior to extraction to prevent clumping.

- 12.4.2** Assemble and pre-extract the Soxhlet apparatus per Sections 12.3.1-12.3.4, except use the methylene chloride:hexane (1:1) mixture for the pre-extraction and rinsing and omit the quartz sand.
- 12.4.3** Reassemble the pre-extracted Soxhlet apparatus and add a fresh charge of methylene chloride:hexane to the reflux flask.
- 12.4.4** Transfer the sample/sodium sulfate mixture (Section 12.4.1) to the Soxhlet thimble, and install the thimble in the Soxhlet apparatus.
- 12.4.5** Rinse the beaker with several portions of solvent mixture and add to the thimble. Fill the thimble/receiver with solvent. Extract for 18-24 hours.
- 12.4.6** After extraction, cool and disassemble the apparatus.
- 12.4.7** Quantitatively transfer the extract to a macro-concentration device (Section 12.6), and concentrate to near dryness. Set aside the concentration apparatus for re-use.
- 12.4.8** Complete the removal of the solvent using the nitrogen blowdown procedure (Section 12.7) and a water bath temperature of 60 °C. Weigh the receiver, record the weight, and return the receiver to the blowdown apparatus, concentrating the residue until a constant weight is obtained.
- 12.4.9** Percent lipid determination—The lipid content is determined by extraction of tissue with the same solvent system (methylene chloride:hexane) that was used in EPA's National Dioxin Study (Reference 16) so that lipid contents are consistent with that study.
- 12.4.9.1** Redissolve the residue in the receiver in hexane and spike 1.0 mL of the Labeled cleanup standard spiking solution (Section 7.13) into the solution.
- 12.4.9.2** Transfer the residue/hexane to the anthropogenic isolation column (Section 13.6), retaining the boiling chips in the concentration apparatus. Use several rinses to assure that all material is transferred. If necessary, sonicate or heat the receiver slightly to assure that all material is re-dissolved. Allow the receiver to dry. Weigh the receiver and boiling chips.
- 12.4.9.3** Calculate the lipid content to the nearest three significant figures as follows:

$$\text{Percent lipid} = \frac{\text{Weight of residue (g)}}{\text{Weight of tissue (g)}} \times 100$$

12.4.9.4 The laboratory should determine the lipid content of the blank, IPR, and OPR to assure that the extraction system is working effectively.

12.5 Back-extraction with base and acid.

12.5.1 Back-extraction may not be necessary for some samples. For some samples, the presence of color in the extract may indicate that back-extraction is necessary. If back-extraction is not performed, spike 1.0 mL of the Labeled cleanup standard spiking solution (Section 7.13) into the extract and concentrate the extract for cleanup or analysis (Section 12.7). If back-extraction is necessary, spike 1.0 mL of the Labeled cleanup standard spiking solution (Section 7.13) into the separatory funnels containing the sample and QC extracts from Section 12.2.3.4 or 12.3.9.

12.5.2 Partition the extract against 50 mL of potassium hydroxide solution (Section 7.1.1). Shake for 2 minutes with periodic venting into a hood. Remove and discard the aqueous layer. Repeat the base washing until no color is visible in the aqueous layer, to a maximum of four washings. Minimize contact time between the extract and the base to prevent degradation of the CBs. Stronger potassium hydroxide solutions may be employed for back-extraction, provided that the laboratory meets the specifications for labeled compound recovery and demonstrates acceptable performance using the procedure in Section 9.2.

12.5.3 Partition the extract against 50 mL of sodium chloride solution (Section 7.1.4) in the same way as with base. Discard the aqueous layer.

12.5.4 Partition the extract against 50 mL of sulfuric acid (Section 7.1.2) in the same way as with base. Repeat the acid washing until no color is visible in the aqueous layer, to a maximum of four washings.

12.5.5 Repeat the partitioning against sodium chloride solution and discard the aqueous layer.

12.5.6 Pour each extract through a drying column containing 7 to 10 cm of granular anhydrous sodium sulfate (Section 7.2.1). Rinse the separatory funnel with 30 to 50 mL of solvent, and pour through the drying column. Collect each extract in a round-bottom flask. Re-concentrate the sample and QC aliquots per Sections 12.6-12.7, and clean up the samples and QC aliquots per Section 13.

12.6 Macro-concentration—Extracts in toluene are concentrated using a rotary evaporator or a heating mantle; extracts in methylene chloride or hexane are concentrated using a rotary evaporator, heating mantle, or Kuderna-Danish apparatus.

Note: *In the concentration procedures below, the extract must not be allowed to concentrate to dryness because the mono- through tri-chlorobiphenyls may be totally or partially lost.*

12.6.1 Rotary evaporation—Concentrate the extracts in separate round-bottom flasks.

12.6.1.1 Assemble the rotary evaporator according to manufacturer's instructions, and warm the water bath to 45 °C. On a daily basis, pre-clean the rotary evaporator by concentrating 100 mL of clean extraction solvent through the system. Archive both the concentrated solvent and the solvent in the catch flask for a contamination check if necessary. Between samples, three 2- to 3-mL aliquots of solvent should be rinsed down the feed tube into a waste beaker.

12.6.1.2 Attach the round-bottom flask containing the sample extract to the rotary evaporator. Slowly apply vacuum to the system, and begin rotating the sample flask.

12.6.1.3 Lower the flask into the water bath, and adjust the speed of rotation and the temperature as required to complete concentration in 15 to 20 minutes. At the proper rate of concentration, the flow of solvent into the receiving flask will be steady, but no bumping or visible boiling of the extract will occur.

Note: *If the rate of concentration is too fast, analyte loss may occur.*

12.6.1.4 When the liquid in the concentration flask has reached an apparent volume of approximately 2 mL, remove the flask from the water bath and stop the rotation. Slowly and carefully admit air into the system. Be sure not to open the valve so quickly that the sample is blown out of the flask. Rinse the feed tube with approximately 2 mL of solvent.

12.6.1.5 Proceed to Section 12.6.4 for preparation for back-extraction or micro-concentration and solvent exchange.

12.6.2 Heating mantle—Concentrate the extracts in separate round-bottom flasks.

12.6.2.1 Add one or two clean boiling chips to the round-bottom flask, and attach a three-ball macro Snyder column. Prewet the column by adding approximately 1 mL of solvent through the top. Place the round-bottom flask in a heating mantle, and apply heat as required to complete the concentration in 15 to 20 minutes. At the proper rate

of distillation, the balls of the column will actively chatter, but the chambers will not flood.

12.6.2.2 When the liquid has reached an apparent volume of approximately 10 mL, remove the round-bottom flask from the heating mantle and allow the solvent to drain and cool for at least 10 minutes. Remove the Snyder column and rinse the glass joint into the receiver with small portions of solvent.

12.6.2.3 Proceed to Section 12.6.4 for preparation for back-extraction or micro-concentration and solvent exchange.

12.6.3 Kuderna-Danish (K-D)—Concentrate the extracts in separate 500-mL K-D flasks equipped with 10-mL concentrator tubes. The K-D technique is used for solvents such as methylene chloride and hexane. Toluene is difficult to concentrate using the K-D technique unless a water bath fed by a steam generator is used.

12.6.3.1 Add 1 to 2 clean boiling chips to the receiver. Attach a three-ball macro Snyder column. Prewet the column by adding approximately 1 mL of solvent through the top. Place the K-D apparatus in a hot water bath so that the entire lower rounded surface of the flask is bathed with steam.

12.6.3.2 Adjust the vertical position of the apparatus and the water temperature as required to complete the concentration in 15 to 20 minutes. At the proper rate of distillation, the balls of the column will actively chatter but the chambers will not flood.

12.6.3.3 When the liquid has reached an apparent volume of 1 mL, remove the K-D apparatus from the bath and allow the solvent to drain and cool for at least 10 minutes. Remove the Snyder column and rinse the flask and its lower joint into the concentrator tube with 1 to 2 mL of solvent. A 5-mL syringe is recommended for this operation.

12.6.3.4 Remove the three-ball Snyder column, add a fresh boiling chip, and attach a two ball micro Snyder column to the concentrator tube. Prewet the column by adding approximately 0.5 mL of solvent through the top. Place the apparatus in the hot water bath.

12.6.3.5 Adjust the vertical position and the water temperature as required to complete the concentration in 5 to 10 minutes. At the proper rate of distillation, the balls of the column will actively chatter but the chambers will not flood.

12.6.3.6 When the liquid reaches an apparent volume of 0.5 mL, remove the apparatus from the water bath and allow to drain and cool for at least 10 minutes.

12.6.3.7 Proceed to 12.6.4 for preparation for back-extraction or micro-concentration and solvent exchange.

12.6.4 Preparation for back-extraction or micro-concentration and solvent exchange.

12.6.4.1 For back-extraction (Section 12.5), transfer the extract to a 250-mL separatory funnel. Rinse the concentration vessel with small portions of hexane, adjust the hexane volume in the separatory funnel to 10 to 20 mL, and proceed to back-extraction (Section 12.5).

12.6.4.2 For determination of the weight of residue in the extract, or for clean-up procedures other than back-extraction, transfer the extract to a blowdown vial using 2-3 rinses of solvent. Proceed with micro-concentration and solvent exchange (Section 12.7).

12.7 Micro-concentration and solvent exchange.

12.7.1 Extracts to be subjected to GPC cleanup are exchanged into methylene chloride. Extracts to be cleaned up using silica gel, carbon, Florisil, and/or HPLC are exchanged into hexane.

12.7.2 Transfer the vial containing the sample extract to a nitrogen blowdown device. Adjust the flow of nitrogen so that the surface of the solvent is just visibly disturbed.

Note: *A large vortex in the solvent may cause analyte loss.*

12.7.3 Lower the vial into a 45 °C water bath and continue concentrating.

12.7.3.1 If the extract or an aliquot of the extract is to be concentrated to dryness for weight determination (Sections 12.4.8 and 13.6.4), blow dry until a constant weight is obtained.

12.7.3.2 If the extract is to be concentrated for injection into the GC/MS or the solvent is to be exchanged for extract cleanup, proceed as follows:

12.7.4 When the volume of the liquid is approximately 100 μ L, add 2 to 3 mL of the desired solvent (methylene chloride for GPC and HPLC, or hexane for the other

cleanups) and continue concentration to approximately 100 μL . Repeat the addition of solvent and concentrate once more.

- 12.7.5** If the extract is to be cleaned up by GPC, adjust the volume of the extract to 5.0 mL with methylene chloride. If the extract is to be cleaned up by HPLC, concentrate the extract to 1.0 mL. Proceed with GPC or HPLC cleanup (Section 13.2 or 13.5, respectively).
- 12.7.6** If the extract is to be cleaned up by column chromatography (silica gel, Carbopak/Celite, or Florisil), bring the final volume to 1.0 mL with hexane. Proceed with column cleanup (Sections 13.3, 13.4, or 13.7).
- 12.7.7** If the extract is to be concentrated for injection into the GC/MS (Section 14), quantitatively transfer the extract to a 0.3-mL conical vial for final concentration, rinsing the larger vial with hexane and adding the rinse to the conical vial. Reduce the volume to approximately 100 μL . Add 20 μL of nonane to the vial, and evaporate the solvent to the level of the nonane. Seal the vial and label with the sample number. Store in the dark at room temperature until ready for GC/MS analysis. If GC/MS analysis will not be performed on the same day, store the vial at <-10 °C.

13.0 Extract cleanup

- 13.1** Cleanup may not be necessary for relatively clean samples (e.g., treated effluents, groundwater, drinking water). If particular circumstances require the use of a cleanup procedure, the laboratory may use any or all of the procedures below or any other appropriate procedure. Before using a cleanup procedure, the laboratory must demonstrate that the requirements of Section 9.2 can be met using the cleanup procedure.
- 13.1.1** Gel permeation chromatography (Section 13.2) removes high molecular weight interferences that cause GC column performance to degrade. It should be used for all soil and sediment extracts. It may be used for water extracts that are expected to contain high molecular weight organic compounds (e.g., polymeric materials, humic acids). It should also be used for tissue extracts after initial cleanup on the anthropogenic isolation column (Section 13.6).
- 13.1.2** Acid, neutral, and basic silica gel (Section 13.3) and Florisil (Section 13.7) are used to remove non-polar and polar interferences.
- 13.1.3** Carbopak/Celite (Section 13.4) can be used to separate CBs 77, 126, and 169 from the mono- and di- ortho-substituted CBs, if desired.
- 13.1.4** HPLC (Section 13.5) is used to provide specificity for certain congeners and congener groups.

13.1.5 The anthropogenic isolation column (Section 13.6) is used for removal of lipids from tissue samples.

13.2 Gel permeation chromatography (GPC)

13.2.1 Column packing

13.2.1.1 Place 70 to 75 g of SX-3 Bio-beads (Section 6.7.1.1) in a 400- to 500-mL beaker.

13.2.1.2 Cover the beads with methylene chloride and allow to swell overnight (a minimum of 12 hours).

13.2.1.3 Transfer the swelled beads to the column (Section 6.7.1.1) and pump solvent through the column, from bottom to top, at 4.5 to 5.5 mL/minute prior to connecting the column to the detector.

13.2.1.4 After purging the column with solvent for 1 to 2 hours, adjust the column head pressure to 7 to 10 psig and purge for 4 to 5 hours to remove air. Maintain a head pressure of 7 to 10 psig. Connect the column to the detector (Section 6.7.1.4).

13.2.2 Column calibration

13.2.2.1 Load 5 mL of the GPC calibration solution (Section 7.4) into the sample loop.

13.2.2.2 Inject the GPC calibration solution and record the signal from the detector. The elution pattern will be corn oil, BEHP, methoxychlor, perylene, and sulfur.

13.2.2.3 Set the "dump time" to allow >85% removal of BEHP and >85% collection of methoxychlor.

13.2.2.4 Set the "collect time" to the time of the sulfur peak maximum.

13.2.2.5 Verify calibration with the GPC calibration solution after every 20 extracts. Calibration is verified if the recovery of the methoxychlor is greater than 85%. If calibration is not verified, the system must be recalibrated using the GPC calibration solution, and the previous sample batch must be re-extracted and cleaned up using the calibrated GPC system.

13.2.3 Extract cleanup—GPC requires that the column not be overloaded. The column specified in this Method is designed to handle a maximum of 0.5 g of material

from an aqueous, soil, or mixed-phase sample in a 5-mL extract, and has been shown to handle 1.5 g of lipid from a tissue sample in a 5-mL extract. If the extract is known or expected to contain more than these amounts, the extract is split into aliquots for GPC, and the aliquots are combined after elution from the column. The residue content of the extract may be obtained gravimetrically by evaporating the solvent from a 50- μ L aliquot.

- 13.2.3.1** Filter the extract or load through the filter holder (Section 6.7.1.3) to remove particles. Load the 5.0-mL extract onto the column.
- 13.2.3.2** Elute the extract using the calibration data determined in Section 13.2.2. Collect the eluate in a clean 400- to 500-mL beaker. Allow the system to rinse for additional 10 minutes before injecting the next sample.
- 13.2.3.3** Rinse the sample loading tube thoroughly with methylene chloride between extracts to prepare for the next sample.
- 13.2.3.4** If an extract is encountered that could overload the GPC column to the extent that carry-over could occur, a 5.0-mL methylene chloride blank must be run through the system to check for carry-over.
- 13.2.3.5** Concentrate the eluate per Sections 12.6 and 12.7 for further cleanup or injection into the GC/MS.

13.3 Silica gel cleanup.

- 13.3.1** Place a glass-wool plug in a 15-mm ID chromatography column (Section 6.7.4.2). Pack the column bottom to top with: 1 g silica gel (Section 7.5.1.1), 4 g basic silica gel (Section 7.5.1.3), 1 g silica gel, 8 g acid silica gel (Section 7.5.1.2), 2 g silica gel, and 4 g granular anhydrous sodium sulfate (Section 7.2.1). Tap the column to settle the adsorbents.
- 13.3.2** Pre-elute the column with 50 to 100 mL of hexane. Close the stopcock when the hexane is within 1 mm of the sodium sulfate. Discard the eluate. Check the column for channeling. If channeling is present, discard the column and prepare another.
- 13.3.3** Apply the concentrated extract to the column. Open the stopcock until the extract is within 1 mm of the sodium sulfate.
- 13.3.4** Rinse the receiver twice with 1-mL portions of hexane, and apply separately to the column. Elute the CBs with 25 mL of hexane and collect the eluate.

- 13.3.5** Concentrate the eluate per Section 12.6 and 12.7 for further cleanup or injection into the HPLC or GC/MS.
- 13.3.6** For extracts of samples known to contain large quantities of other organic compounds, it may be advisable to increase the capacity of the silica gel column. This may be accomplished by increasing the strengths of the acid and basic silica gels. The acid silica gel (Section 7.5.1.2) may be increased in strength to as much as 40% w/w (6.7 g sulfuric acid added to 10 g silica gel). The basic silica gel (Section 7.5.1.3) may be increased in strength to as much as 33% w/w (50 mL 1N NaOH added to 100 g silica gel), or the potassium silicate (Section 7.5.1.4) may be used.

Note: *The use of stronger acid silica gel (44% w/w) may lead to charring of organic compounds in some extracts. The charred material may retain some of the analytes and lead to lower recoveries of the CBs. Increasing the strengths of the acid and basic silica gel may also require different volumes of hexane than those specified above to elute the analytes from the column. The performance of the Method after such modifications must be verified by the procedure in Section 9.2.*

13.4 Carbon column (Reference 17)

- 13.4.1** Cut both ends from a 50-mL disposable serological pipet (Section 6.7.3.2) to produce a 20-cm column. Fire-polish both ends and flare both ends if desired. Insert a glass-wool plug at one end, and pack the column with 3.6 g of Carbowax/Celite (Section 7.5.2.3) to form an adsorbent bed 20 cm long. Insert a glass-wool plug on top of the bed to hold the adsorbent in place.
- 13.4.2** Pre-elute the column with 20 mL each in succession of toluene, methylene chloride, and hexane.
- 13.4.3** When the solvent is within 1 mm of the column packing, apply the n-hexane sample extract to the column. Rinse the sample container twice with 1-mL portions of hexane and apply separately to the column. Apply 2 mL of hexane to complete the transfer.
- 13.4.4** Elute the column with 25 mL of n-hexane and collect the eluate. This fraction will contain the mono- and di-ortho CBs. If carbon particles are present in the eluate, filter through glass-fiber filter paper.
- 13.4.5** Elute the column with 15 mL of methanol and discard the eluate. The fraction discarded will contain residual lipids and other potential interferents, if present.
- 13.4.6** Elute the column with 15 mL of toluene and collect the eluate. This fraction will

contain CBs 77, 126, and 169. If carbon particles are present in the eluate, filter through glass-fiber filter paper.

13.4.7 Concentrate the fractions per Section 12.6 and 12.7 for further cleanup or injection into the HPLC or GC/MS.

13.5 HPLC (References 4 and 18).

13.5.1 Column calibration.

13.5.1.1 Prepare a calibration standard containing the Toxics and other congeners of interest at the concentrations of the stock solution in Table 3, or at a concentration appropriate to the response of the detector.

13.5.1.2 Inject the calibration standard into the HPLC and record the signal from the detector. Collect the eluant for reuse. Elution will be in the order of the di-ortho, mono-ortho, and non-ortho congeners.

13.5.1.3 Establish the collection time for the congeners of interest. Following calibration, flush the injection system with solvent to ensure that residual CBs are removed from the system.

13.5.1.4 Verify the calibration with the calibration solution after every 20 extracts. Calibration is verified if the recovery of the CBs is 75 to 125% compared to the calibration (Section 13.5.1.1). If calibration is not verified, the system must be recalibrated using the calibration solution, and the previous 20 samples must be re-extracted and cleaned up using the calibrated system.

13.5.2 Extract cleanup—HPLC requires that the column not be overloaded. The column specified in this Method is designed to handle a maximum of 5-50 μg of a given CB, depending on the congener (Reference 18). If the amount of material in the extract will overload the column, split the extract into fractions and combine the fractions after elution from the column.

13.5.2.1 Rinse the sides of the vial containing the sample and adjust to the volume required for the sample loop for injection.

13.5.2.2 Inject the sample extract into the HPLC.

13.5.2.3 Elute the extract using the calibration data determined in Section 13.5.1. Collect the fraction(s) in clean 20-mL concentrator tubes.

13.7.3 Elute the mono-ortho and di-ortho CBs with approx 165 mL of n-hexane and collect the eluate. Elute the non-ortho co-planar CBs with approx 100 mL of 6% ether:hexane and collect the eluate. The exact volumes of solvents will need to be determined for each batch of Florisil. If the mono/di-ortho CBs are not to be separated from the non-ortho co-planar CBs, elute all CBs with 6% ether:hexane.

13.7.4 Concentrate the eluate(s) per Sections 12.6-12.7 for further cleanup or for injection into the HPLC or GC/MS.

14.0 HRGC/HRMS analysis

14.1 Establish the operating conditions given in Section 10.1.

14.2 Add 2 μL of the Labeled injection internal standard spiking solution (Section 7.14) to the 20 μL sample extract immediately prior to injection to minimize the possibility of loss by evaporation, adsorption, or reaction. If an extract is to be reanalyzed and evaporation has occurred, do not add more Labeled injection internal standard spiking solution. Rather, bring the extract back to its previous volume (e.g., 19 μL) with pure nonane (18 μL if 2 μL injections are used).

14.3 Inject 1.0 or 2.0 μL of the concentrated extract containing the Labeled injection internal standards using on-column or splitless injection. The volume injected must be identical to the volume used for calibration (Section 10.3).

14.3.1 Start the GC column initial isothermal hold upon injection. Start MS data collection after the solvent peak elutes.

14.3.2 Monitor the exact m/z's at each LOC throughout the LOC retention time window. Where warranted, monitor m/z's associated with congeners at higher levels of chlorination to assure that fragments are not interfering with the m/z's for congeners at lower levels of chlorination. Also where warranted, monitor m/z's associated with interferents expected to be present.

14.3.3 Stop data collection after $^{13}\text{C}_{12}$ -DeCB has eluted. Return the column to the initial temperature for analysis of the next extract or standard.

15.0 System and laboratory performance

15.1 At the beginning of each 12-hour shift during which analyses are performed, GC/MS system performance and calibration are verified for all native CBs and labeled compounds. For these tests, analysis of the CS-3 calibration verification (VER) standard (Section 7.10.1 and Table 5) and the Diluted combined 209 congener solution (Section 7.10.2.2 and Table 5) must be used to verify all performance criteria. Adjustment and/or recalibration (Section 10) must be performed until all performance criteria are met. Only after all performance criteria are met may samples, blanks, IPRs, and OPRs be analyzed.

15.2 MS resolution—Static resolving power checks must be performed at the beginning and at the end of each shift per Sections 10.2.1. If analyses are performed on successive shifts, only the beginning of shift static resolving power check is required. If the requirement in Section 10.2.1 cannot be met, the problem must be corrected before analyses can proceed. If any of the samples in the previous shift may be affected by poor resolution, those samples must be re-analyzed.

15.3 Calibration verification

15.3.1 Inject the VER (CS-3) standard using the procedure in Section 14.

15.3.2 The m/z abundance ratios for all CBs must be within the limits in Table 8; otherwise, the mass spectrometer must be adjusted until the m/z abundance ratios fall within the limits specified when the verification test is repeated. If the adjustment alters the resolution of the mass spectrometer, resolution must be verified (Section 10.2.1) prior to repeat of the verification test.

15.3.3 The GC peak representing each native CB and labeled compound in the VER standard must be present with a S/N of at least 10; otherwise, the mass spectrometer must be adjusted and the verification test repeated.

15.3.4 Compute the concentration of the Toxics/LOC CBs by isotope dilution (Section 17.1). These concentrations are computed based on the calibration data in Section 10.

15.3.5 For each compound, compare the concentration with the calibration verification limit in Table 6. If all compounds meet the acceptance criteria, calibration has been verified and analysis of standards and sample extracts may proceed. If, however, any compound fails its respective limit, the measurement system is not performing properly. In this event, prepare a fresh calibration standard or correct the problem and repeat the resolution (Section 15.2) and verification (Section 15.3) tests, or recalibrate (Section 10). If recalibration is required, recalibration for the 209 congeners (Section 10.5) must also be performed.

15.4 Retention times and GC resolution

15.4.1 Retention times.

15.4.1.1 Absolute—The absolute retention times of the Labeled Toxics/LOC/window defining standard congeners (Section 7.12) in the verification test (Section 15.3) must be within ± 15 seconds of the respective retention times in the calibration or, if an alternate column or column system is employed, within ± 15 seconds of the respective retention times in the calibration for the alternate column or column system (Section 6.9.1.2).

15.4.1.2 Relative—The relative retention times of native CBs and labeled compounds in the verification test (Section 15.3) must be within their respective RRT limits in Table 2 or, if an alternate column or column system is employed, within their respective RRT limits for the alternate column or column system (Section 6.9.1.2).

15.4.1.3 If the absolute or relative retention time of any compound is not within the limits specified, the GC is not performing properly. In this event, adjust the GC and repeat the verification test (Section 15.3) or recalibrate (Section 10), or replace the GC column and either verify calibration or recalibrate.

15.4.2 GC resolution and minimum analysis time

15.4.2.1 As a final step in calibration verification, inject the Diluted combined 209 congener solution (Section 7.10.2.2 and Table 5).

15.4.2.2 The resolution and minimum analysis time specifications in Sections 6.9.1.1.2 and 6.9.1.1.1, respectively, must be met for the SPB-octyl column or, if an alternate column or column system is employed, must be met as specified for the alternate column or column system (Section 6.9.1.2). If these specifications are not met, the GC analysis conditions must be adjusted until the specifications are met, or the column must be replaced and the calibration verification tests repeated (Sections 15.4.1 through 15.4.2.2), or the system must be recalibrated (Section 10).

15.4.2.3 After the resolution and minimum analysis time specifications are met, update the retention times, relative retention times, and response factors for the all congeners except the Toxics and LOC CBs. For the Toxics and LOC CBs, the multi-point calibration data must be used (see Section 10.4 and 15.3).

15.5 Ongoing precision and recovery.

15.5.1 Analyze the extract of the ongoing precision and recovery (OPR) aliquot (Section 11.4.2.5, 11.5.4, 11.6.2, or 11.8.3.2) prior to analysis of samples from the same batch.

15.5.2 Compute the percent recovery of the Toxics/LOC CBs by isotope dilution (Section 10.4). Compute the percent recovery of each labeled compound by the internal standard method (Section 10.5).

15.5.3 For the Toxics/LOC CBs and labeled compounds, compare the recovery to the OPR limits given in Table 6. If all compounds meet the acceptance criteria,

system performance is acceptable and analysis of blanks and samples may proceed. If, however, any individual concentration falls outside of the range given, the extraction/concentration processes are not being performed properly for that compound. In this event, correct the problem, re-prepare, extract, and clean up the sample batch and repeat the ongoing precision and recovery test (Section 15.5).

15.5.4 If desired, add results that pass the specifications in Section 15.5.3 to initial and previous ongoing data for each compound in each matrix. Update QC charts to form a graphic representation of continued laboratory performance. Develop a statement of laboratory accuracy for each congener in each matrix type by calculating the average percent recovery (R) and the standard deviation of percent recovery (S_R). Express the accuracy as a recovery interval from $R - 2S_R$ to $R + 2S_R$. For example, if $R = 95\%$ and $S_R = 5\%$, the accuracy is 85 to 105%.

15.6 Blank—Analyze the Method blank extracted with each sample batch immediately following analysis of the OPR aliquot to demonstrate freedom from contamination and freedom from carryover from the OPR analysis. The results of the analysis of the blank must meet the specifications in Section 9.5.2 before sample analyses may proceed.

16.0 Qualitative determination

A CB or labeled compound is identified in a standard, blank, or sample when all of the criteria in Sections 16.1 through 16.4 are met.

- 16.1** The signals for the two exact m/z 's in Table 7 must be present and must maximize within the same two scans.
- 16.2** The signal-to-noise ratio (S/N) for the GC peak at each exact m/z must be greater than or equal to 2.5 for each CB detected in a sample extract, and greater than or equal to 10 for all CBs in the calibration and verification standards (Sections 10.3.3 and 15.3.3).
- 16.3** The ratio of the integrated areas of the two exact m/z 's specified in Table 7 must be within the limit in Table 8, or within ± 15 percent of the ratio in the midpoint (CS-3) calibration or calibration verification (VER), whichever is most recent.
- 16.4** The relative retention time of the peak for a CB must be within the RRT QC limits specified in Table 2 or, if an alternate column or column system is employed, within its respective RRT QC limits for the alternate column or column system (Section 6.9.1.2).

Note: For native CBs determined by internal standard quantitation, a given CB congener may fall within more than RT window and be mis-identified unless the RRT windows are made very narrow, as in Table 2. Therefore, consistency of the RT and RRT with other congeners and the labeled compounds may be required for rigorous congener identification. Retention time regression analysis may aid in this identification.

- 16.5** Because of congener overlap and the potential for interfering substances, it is possible that all of the identification criteria (Sections 16.1-16.4) may not be met. It is also possible that loss of one or more chlorines from a highly chlorinated congener may inflate or produce a false concentration for a less-chlorinated congener that elutes at the same retention time. If identification is ambiguous, an experienced spectrometrists (Section 1.4) must determine the presence or absence of the congener.
- 16.6** If the criteria for identification in Sections 16.1-16.5 are not met, the CB has not been identified and the result for that congener may not be reported or used for permitting or regulatory compliance purposes. If interferences preclude identification, a new aliquot of sample must be extracted, further cleaned up, and analyzed.

17.0 Quantitative determination

17.1 Isotope dilution quantitation

17.1.1 By adding a known amount of the Labeled Toxics/LOC/window-defining compounds to every sample prior to extraction, correction for recovery of the CB can be made because the native compound and its labeled analog exhibit similar effects upon extraction, concentration, and gas chromatography. Relative responses (RRs) are used in conjunction with the calibration data in Section 10.4 to determine concentrations in the final extract, so long as labeled compound spiking levels are constant.

17.1.2 Compute the concentrations in the extract of the Native Toxics/LOC CBs using the RRs from the calibration data (Section 10.4) and following equation:

$$C_{ex} \text{ (ng/mL)} = \frac{(AI_n + A2_n) C_l}{(AI_l + A2_l) RR}$$

where:

C_{ex} = The concentration of the PCB in the extract, and the other terms are as defined in Section 10.5.1

17.2 Internal standard quantitation and labeled compound recovery

17.2.1 Compute the concentrations in the extract of the native compounds other than those in the Native Toxics/LOC standard, in the Labeled cleanup standard, and

in the Labeled injection internal standard (except for labeled CB 178) using the response factors determined from the calibration data (Section 10.5) and the following equation:

$$C_{ex} \text{ (ng/mL)} = \frac{(AI_s + A2_s) C_{is}}{(AI_{is} + A2_{is}) RF}$$

where:

C_{ex} = The concentration of the labeled compound in the extract.

The other terms are defined in Section 10.6.1

17.2.2 Using the concentration in the extract determined above, compute the percent recovery of the Labeled Toxics/LOC/window-defining CBs and the Labeled cleanup standard CBs using the following equation:

$$\text{Recovery (\%)} = \frac{\text{Concentration found } (\mu\text{g/mL})}{\text{Concentration spiked } (\mu\text{g/mL})} \times 100$$

17.3 The concentration of a native CB in the solid phase of the sample is computed using the concentration of the compound in the extract and the weight of the solids (Section 11.2.2.3), as follows:

$$\text{Concentration in solid (ng/kg)} = \frac{(C_{ex} \times V_{ex})}{W_s}$$

where:

C_{ex} = The concentration of the compound in the extract.

V_{ex} = The extract volume in mL.

W_s = The sample weight (dry weight) in kg.

17.4 The concentration of a native CB in the aqueous phase of the sample is computed using the concentration of the compound in the extract and the volume of water extracted (Section 11.4), as follows:

$$\text{Concentration in aqueous phase (pg/L)} = \frac{(C_{ex} \times V_{ex})}{V_s}$$

where:

C_{ex} = The concentration of the compound in the extract.

V_{ex} = The extract volume in mL.

V_s = The sample volume in liters.

17.5 If the SICP area at either quantitation m/z for any congener exceeds the calibration range of the system, dilute the sample extract by the factor necessary to bring the concentration within the calibration range, adjust the concentration of the Labeled injection internal standard to 100 pg/ μ L in the extract, and analyze an aliquot of this diluted extract. If the

CBs cannot be measured reliably by isotope dilution, dilute and analyze an aqueous sample or analyze a smaller portion of a soil, tissue, or mixed-phase sample. Adjust the CB congener concentrations, detection limits, and minimum levels to account for the dilution.

- 17.6** Results are reported to three significant figures for the CBs and labeled compounds found in all standards, blanks, and samples.

17.6.1 Reporting units and levels.

17.6.1.1 Aqueous samples—Report results in pg/L (parts-per-quadrillion).

17.6.1.2 Samples containing greater than 1% solids (soils, sediments, filter cake, compost)—Report results in ng/kg based on the dry weight of the sample. Report the percent solids so that the result may be converted to aqueous units.

17.6.1.3 Tissues—Report results in ng/kg of wet tissue, not on the basis of the lipid content of the tissue. Report the percent lipid content, so that the data user can calculate the concentration on a lipid basis if desired.

17.6.1.4 Reporting level.

17.6.1.4.1 Results above the minimum level of quantitation (ML) are reported for the analysis of blanks, standards, and samples. The estimated minimum levels (EMLs) in Table 2 are based on common laboratory contamination levels. A laboratory may establish an ML for a CB lower than the EMLs in Table 2. MLs may be established as low as the lowest calibration point (Table 5) provided that the concentration of the congener in a minimum of 10 blanks for a sample medium (e.g., water, soil, sludge, tissue) is significantly below the EML in Table 2. Significant means that the ML for the congener is no less than the average (mean) plus 2 standard deviations above the level in the minimum of 10 blanks (Reference 20). The blanks must be analyzed during the same period that the sample is analyzed, ideally over an approximately 1-month period.

17.6.1.4.2 Standards (VER, IPR, OPR) and samples—Report the result for each congener at or above the ML (or EML Table 2) to 3 significant figures. Report results below the ML (or EML) as <ML (where ML is the

concentration at the ML) or as required by the regulatory authority or permit.

17.6.1.4.3 Blanks—Report results above the ML (or EML) to 3 significant figures. Report results below the ML but above the MDL (or EMDL) to 2 significant figures. Report results below the MDL as <MDL (where MDL is the concentration at the MDL) or as required by the regulatory authority or permit.

17.6.1.4.4 Blank correction—Blank-corrected results may be reported in addition to reporting of separate results for samples (Section 17.6.1.4.1) and blanks (Section 17.6.1.4.2). The recommended procedure for blank correction (Reference 20) is that a result is significantly above the blank level, and the level in the blank may be subtracted, if the result is greater than the mean plus 2 standard deviations of results of analyses of 10 or more blanks for a sample medium.

17.6.2 Results for a CB in a sample that has been diluted are reported at the least dilute level at which the area at the quantitation m/z is within the calibration range (Section 17.5).

17.6.3 For a CB having a labeled analog, report results at the least dilute level at which the area at the quantitation m/z is within the calibration range (Section 17.5) and the labeled compound recovery is within the normal range for the Method (Section 9.3 and Table 6).

17.6.4 If requested, the total concentration of all congeners at a given level of chlorination (i.e., total TrCB, total PeCB, total HxCB) may be reported by summing the concentrations of all congeners identified at that LOC, including both the Toxics and other congeners.

18.0 Analysis of complex samples

18.1 Some samples may contain high levels (>10 ng/L; >1000 ng/kg) of the compounds of interest, interfering compounds, and/or polymeric materials. Some extracts may not concentrate to 20 μ L (Section 12.7); others may overload the GC column and/or mass spectrometer. Fragment ions from congeners at higher levels of chlorination may interfere with determination of congeners at lower levels of chlorination.

18.2 Analyze a smaller aliquot of the sample (Section 17.5) when the extract will not concentrate to 20 μ L after all cleanup procedures have been exhausted. If a smaller aliquot of soils or mixed-phase samples is analyzed, attempt to assure that the sample is

representative.

- 18.3** Perform integration of peak areas and calculate concentrations manually when interferences preclude computerized calculations.
- 18.4** Several laboratories have reported that backgrounds of many of the CB congeners are difficult to eliminate, and that these backgrounds can interfere with the determination of the CBs in environmental samples. Backgrounds of Toxics with IUPAC numbers 105, 114, 118, 123, 156, 157, and 167 are common. The effects of contamination on results for these congeners should be understood in order to make a reliable determination.
- 18.5** Recovery of labeled compounds—In most samples, recoveries of the labeled compounds will be similar to those from reagent water or from the alternate matrix (Section 7.6).
- 18.5.1** If the recovery of any of the labeled compounds is outside of the normal range (Table 6), a diluted sample must be analyzed (Section 17.5).
- 18.5.2** If the recovery of any of the labeled compounds in the diluted sample is outside of normal range, the calibration verification standard (Section 7.10.1 and Table 5) must be analyzed and calibration verified (Section 15.3).
- 18.5.3** If the calibration cannot be verified, a new calibration must be performed and the original sample extract reanalyzed.
- 18.5.4** If the calibration is verified and the diluted sample does not meet the limits for labeled compound recovery, the Method does not apply to the sample being analyzed and the result may not be reported or used for permitting or regulatory compliance purposes. In this case, alternate extraction and cleanup procedures in this Method or an alternate GC column must be employed to resolve the interference. If all cleanup procedures in this Method and an alternate GC column have been employed and labeled compound recovery remains outside of the normal range, extraction and/or cleanup procedures that are beyond this scope of this Method will be required to analyze the sample.

19.0 Pollution prevention

- 19.1** Pollution prevention encompasses any technique that reduces or eliminates the quantity or toxicity of waste at the point of generation. Many opportunities for pollution prevention exist in laboratory operation. EPA has established a preferred hierarchy of environmental management techniques that places pollution prevention as the management option of first choice. Whenever feasible, laboratory personnel should use pollution prevention techniques to address waste generation. When wastes cannot be reduced feasibly at the source, the Agency recommends recycling as the next best option.
- 19.2** The CBs in this Method are used in extremely small amounts and pose little threat to the

environment when managed properly. Standards should be prepared in volumes consistent with laboratory use to minimize the disposal of excess volumes of expired standards.

- 19.3** For information about pollution prevention that may be applied to laboratories and research institutions, consult *Less is Better: Laboratory Chemical Management for Waste Reduction*, available from the American Chemical Society's Department of Governmental Relations and Science Policy, 1155 16th Street NW, Washington DC 20036, 202/872-4477.

20.0 Waste management

- 20.1** The laboratory is responsible for complying with all Federal, State, and local regulations governing waste management, particularly the hazardous waste identification rules and land disposal restrictions, and to protect the air, water, and land by minimizing and controlling all releases from fume hoods and bench operations. Compliance is also required with any sewage discharge permits and regulations. An overview of requirements can be found in *Environmental Management Guide for Small Laboratories* (EPA 233-B-98-001).
- 20.2** Samples containing HCl or H₂SO₄ to pH <2 are hazardous and must be neutralized before being poured down a drain or must be handled as hazardous waste.
- 20.3** The CBs decompose above 800 °C. Low-level waste such as absorbent paper, tissues, animal remains, and plastic gloves may be burned in an appropriate incinerator. Gross quantities (milligrams) should be packaged securely and disposed of through commercial or governmental channels that are capable of handling extremely toxic wastes.
- 20.4** Liquid or soluble waste should be dissolved in methanol or ethanol and irradiated with ultraviolet light with a wavelength shorter than 290 nm for several days. Use F40 BL or equivalent lamps. Analyze liquid wastes, and dispose of the solutions when the CBs can no longer be detected.
- 20.5** For further information on waste management, consult *The Waste Management Manual for Laboratory Personnel* and *Less is Better-Laboratory Chemical Management for Waste Reduction*, available from the American Chemical Society's Department of Government Relations and Science Policy, 1155 16th Street N.W., Washington, D.C. 20036.

21.0 Method performance

Method 1668A was validated and preliminary data were collected in a single laboratory (Reference 21). The original version of Method 1668 was validated in two single-laboratory studies. Figure 8 is a chromatogram showing method performance at each level of chlorination.

22.0 References

- 1 Van den Berg, Linda Birnbaum, Albetus T.C. Bosveld, Björn Brunström, Philip Cook, Mark Feeley, John P. Giesy, Annika Hanberg, Ryuichi Hasegawa, Sean W. Kennedy, Timothy Kubiak, John Christian Larsen, F.X. Rolaf van Leeuwen, A.K. Djien Liem, Cynthia Nott, Richard E. Peterson, Lorenz Poellinger, Stephen Safe, Donald Tillitt, Mats Tysklind, Maged Younes, Fredrik Wærn, and Tim Zacharewski, *Environmental Health Perspectives* 106:12, 775-792, 1998.
- 2 "Sampling and Analytical Methods of the National Status and Trends Program Mussel Watch Project: 1993-1996 Update," NOAA Technical Memorandum NOS ORCS 130, Coastal Monitoring and Bioeffects Assessment Division, Office of Ocean Resources Conservation and Assessment, National Ocean Service, National Oceanic and Atmospheric Administration, U.S. Department of Commerce, N/ORCA2, SSMC4, 1305 East-West Highway, Silver Spring, MD 20910, p 3, 1998.
- 3 Kuehl, D.W., B.C. Butterworth, J. Libal, and P. Marquis, "An Isotope Dilution High Resolution Gas Chromatography-High Resolution Mass Spectrometric Method for the Determination of Coplanar Polychlorinated Biphenyls: Application to Fish and Marine Mammals," *Chemosphere* 22:9-10, 849-858, 1991.
- 4 Echols, Kathy, Robert Gale, Donald E. Tillitt, Ted Schwartz, and Jerome O'Laughlin, *Environmental Toxicology and Chemistry* 16:8 1590-1597, 1997.
- 5 "Analysis of Coplanar CBs," Axys Environmental Systems Ltd., Fax from Mary McFarland to Dale Rushneck dated November 25, 1994, available from the EPA Sample Control Center, operated by DynCorp I&ET, 6101 Stevenson Ave., Alexandria, VA 22304 (703-461-2000).
- 6 "Working with Carcinogens," Department of Health, Education, & Welfare, Public Health Service, Centers for Disease Control, NIOSH, Publication 77-206, August 1977, NTIS PB-277256.
- 7 "OSHA Safety and Health Standards, General Industry," OSHA 2206, 29 *CFR* 1910.
- 8 "Safety in Academic Chemistry Laboratories," ACS Committee on Chemical Safety, 1979.
- 9 "Standard Methods for the Examination of Water and Wastewater," 18th edition and later revisions, American Public Health Association, 1015 15th St, N.W., Washington, DC 20005, 1-35: Section 1090 (Safety), 1992.
- 10 "Method 613—2,3,7,8-Tetrachlorodibenzo-*p*-dioxin," 40 *CFR* 136 (49 *FR* 43234), October 26, 1984, Section 4.1.
- 11 Lamparski, L.L., and Nestruck, T.J., "Novel Extraction Device for the Determination of Chlorinated Dibenzo-*p*-dioxins (PCDDs) and Dibenzofurans (PCDFs) in Matrices

- Containing Water," *Chemosphere*, 19:27-31, 1989.
- 12 Provost, L.P., and Elder, R.S., "Interpretation of Percent Recovery Data," *American Laboratory*, 15: 56-83, 1983.
 - 13 "Standard Practice for Sampling Water," ASTM Annual Book of Standards, ASTM, 1916 Race Street, Philadelphia, PA 19103-1187, 1980.
 - 14 "Methods 330.4 and 330.5 for Total Residual Chlorine," USEPA, EMSL, Cincinnati, OH 45268, EPA 600/4-70-020, March 1979.
 - 15 "Handbook of Analytical Quality Control in Water and Wastewater Laboratories," USEPA EMSL, Cincinnati, OH 45268, EPA-600/4-79-019, March 1979.
 - 16 "Analytical Procedures and Quality Assurance Plan for the Determination of PCDD/PCDF in Fish", U.S. Environmental Protection Agency, Environmental Research Laboratory, Duluth MN 55804, EPA/600/3-90/022, March 1990.
 - 17 Storr-Hansen, E. and T. Cederberg, "Determination of Coplanar Polychlorinated Biphenyl (CB) Congeners in Seal Tissues by Chromatography on Active Carbon, Dual-Column High Resolution GC/ECD and High Resolution GC/High Resolution MS" *Chemosphere* 24:9, 1181-1196, 1992.
 - 18 Echols, Kathy R., Robert W. Gale, Kevin Feltz, Jerome O'Laughlin, Donal E. Tillitt, and Ted R. Schwartz, *J. Chromatog. A* 811: 135-144, 1998.
 - 19 Tessari, J.D., Personal communication with Dale Rushneck, available from the EPA Sample Control Center, operated by DynCorp I&ET, 6101 Stevenson Ave., Alexandria, VA 22304 (703-461-2000).
 - 20 Ferrario, J.C., C. Byrne, A.E. Dupuy, Jr., "Background Contamination by Coplanar Polychlorinated Biphenyls (PCBs) in Trace Level High Resolution Gas Chromatography/High Resolution Mass Spectrometry (HRGC/HRMS) Analytical Procedures" *Chemosphere* 34:11, 2451-2465, 1997.
 - 21 "Development of a Full Congener Version of Method 1668 and Application to the Analysis of 209 PCB Congeners in Aroclors," Axys Analytical Services, available from the EPA Sample Control Center, operated by DynCorp I&ET, 6101 Stevenson Ave., Alexandria, VA 22304 (703-461-2000).

23.0 Tables and Figures

Table 1. Names, International Union of Pure and Applied Chemistry (IUPAC) numbers, and CAS Registry numbers for native and labeled chlorinated biphenyl (CB) congeners determined by isotope dilution and internal standard HRGC/HRMS.

CB congener ¹	IUPAC number	CAS registry number	Labeled analog	IUPAC analog	CAS registry number
2-MoCB	1	2051-60-7	¹³ C ₁₂ -2-MoCB ²	1L	234432-85-0
3-MoCB	2	2051-61-8			
4-MoCB	3	2051-62-9	¹³ C ₁₂ -4-MoCB ²	3L	208263-77-8
2,2'-DiCB	4	13029-08-8	¹³ C ₁₂ -2,2'-DiCB ²	4L	234432-86-1
2,3-DiCB	5	16605-91-7			
2,3'-DiCB	6	25569-80-6			
2,4-DiCB	7	33284-50-3			
2,4'-DiCB ³	8	34883-43-7			
2,5-DiCB	9	34883-39-1	¹³ C ₁₂ -2,5-DiCB ⁴	9L	250694-89-4
2,6-DiCB	10	33146-45-1			
3,3'-DiCB	11	2050-67-1			
3,4-DiCB	12	2974-92-7			
3,4'-DiCB	13	2974-90-5			
3,5-DiCB	14	34883-41-5			
4,4'-DiCB	15	2050-68-2	¹³ C ₁₂ -4,4'-DiCB ²	15L	208263-67-6
2,2',3-TrCB	16	38444-78-9			
2,2',4-TrCB	17	37680-66-3			
2,2',5-TrCB ³	18	37680-65-2			
2,2',6-TrCB	19	38444-73-4	¹³ C ₁₂ -2,2',6-TrCB ²	19L	234432-87-2
2,3,3'-TrCB	20	38444-84-7			
2,3,4-TrCB	21	55702-46-0			
2,3,4'-TrCB	22	38444-85-8			
2,3,5-TrCB	23	55720-44-0			
2,3,6-TrCB	24	55702-45-9			
2,3',4-TrCB	25	55712-37-3			
2,3',5-TrCB	26	38444-81-4			
2,3',6-TrCB	27	38444-76-7			
2,4,4'-TrCB ³	28	7012-37-5	¹³ C ₁₂ -2,4,4'-TriCB ⁵	28L	208263-76-7
2,4,5-TrCB	29	15862-07-4			
2,4,6-TrCB	30	35693-92-6			
2,4',5-TrCB	31	16606-02-3			
2,4',6-TrCB	32	38444-77-8			
2',3,4-TrCB	33	38444-86-9			
2',3,5-TrCB	34	37680-68-5			
3,3',4-TrCB	35	37680-69-6			
3,3',5-TrCB	36	38444-87-0			
3,4,4'-TrCB	37	38444-90-5	¹³ C ₁₂ -3,4,4'-TrCB ²	37L	208263-79-0
3,4,5-TrCB	38	53555-66-1			
3,4',5-TrCB	39	38444-88-1			
2,2',3,3'-TeCB	40	38444-93-8			

CB congener ¹	IUPAC number	CAS registry number	Labeled analog	IUPAC analog	CAS registry number
2,2',3,4-TeCB	41	52663-59-9			
2,2',3,4'-TeCB	42	36559-22-5			
2,2',3,5-TeCB	43	70362-46-8			
2,2',3,5'-TeCB ³	44	41464-39-5			
2,2',3,6-TeCB	45	70362-45-7			
2,2',3,6'-TeCB	46	41464-47-5			
2,2',4,4'-TeCB	47	2437-79-8			
2,2',4,5-TeCB	48	70362-47-9			
2,2',4,5'-TeCB	49	41464-40-8			
2,2',4,6-TeCB	50	62796-65-0			
2,2',4,6'-TeCB	51	68194-04-7			
2,2',5,5'-TeCB ³	52	35693-99-3	¹³ C ₁₂ -2,2',5,5'-TeCB ⁴	52L	208263-80-3
2,2',5,6'-TeCB	53	41464-41-9			
2,2',6,6'-TeCB	54	15968-05-5	¹³ C ₁₂ -2,2',6,6'-TeCB ²	54L	234432-88-3
2,3,3',4'-TeCB	55	74338-24-2			
2,3,3',4'-TeCB	56	41464-43-1			
2,3,3',5-TeCB	57	70424-67-8			
2,3,3',5'-TeCB	58	41464-49-7			
2,3,3',6-TeCB	59	74472-33-6			
2,3,4,4'-TeCB	60	33025-41-1			
2,3,4,5-TeCB	61	33284-53-6			
2,3,4,6-TeCB	62	54230-22-7			
2,3,4',5-TeCB	63	74472-34-7			
2,3,4',6-TeCB	64	52663-58-8			
2,3,5,6-TeCB	65	33284-54-7			
2,3',4,4'-TeCB ³	66	32598-10-0			
2,3',4,5-TeCB	67	73575-53-8			
2,3',4,5'-TeCB	68	73575-52-7			
2,3',4,6-TeCB	69	60233-24-1			
2,3',4',5-TeCB	70	32598-11-1			
2,3',4',6-TeCB	71	41464-46-4			
2,3',5,5'-TeCB	72	41464-42-0			
2,3',5',6-TeCB	73	74338-23-1			
2,4,4',5-TeCB	74	32690-93-0			
2,4,4',6-TeCB	75	32598-12-2			
2',3,4,5-TeCB	76	70362-48-0			
3,3',4,4'-TeCB ^{3,6}	77	32598-13-3	¹³ C ₁₂ -3,3',4,4'-TeCB ^{2,7}	77L	105600-23-5
3,3',4,5-TeCB	78	70362-49-1			
3,3',4,5'-TeCB	79	41464-48-6			
3,3',5,5'-TeCB	80	33284-52-5			
3,4,4',5-TeCB ⁶	81	70362-50-4	¹³ C ₁₂ -3,4,4',5-TeCB ⁷	81L	208461-24-9
2,2',3,3',4-PeCB	82	52663-62-4			
2,2',3,3',5-PeCB	83	60145-20-2			
2,2',3,3',6-PeCB	84	52663-60-2			
2,2',3,4,4'-PeCB	85	65510-45-4			
2,2',3,4,5-PeCB	86	55312-69-1			

CB congener ¹	IUPAC number	CAS registry number	Labeled analog	IUPAC analog	CAS registry number
2,2',3,4,5'-PeCB	87	38380-02-8			
2,2',3,4,6-PeCB	88	55215-17-3			
2,2',3,4,6'-PeCB	89	73575-57-2			
2,2',3,4',5-PeCB	90	68194-07-0			
2,2',3,4',6-PeCB	91	68194-05-8			
2,2',3,5,5'-PeCB	92	52663-61-3			
2,2',3,5,6-PeCB	93	73575-56-1			
2,2',3,5,6'-PeCB	94	73575-55-0			
2,2',3,5',6-PeCB	95	38379-99-6			
2,2',3,6,6'-PeCB	96	73575-54-9			
2,2',3',4,5-PeCB	97	41464-51-1			
2,2',3',4,6-PeCB	98	60233-25-2			
2,2',4,4',5-PeCB	99	38380-01-7			
2,2',4,4',6-PeCB	100	39485-83-1			
2,2',4,5,5'-PeCB ³	101	37680-73-2	¹³ C ₁₂ -2,2',4,5,5'-PeCB ⁴	101L	104130-39-4
2,2',4,5,6'-PeCB	102	68194-06-9			
2,2',4,5',6-PeCB	103	60145-21-3			
2,2',4,6,6'-PeCB	104	56558-16-8	¹³ C ₁₂ -2,2',4,6,6'-PeCB ²	104L	234432-89-4
2,3,3',4,4'-PeCB ^{3,6}	105	32598-14-4	¹³ C ₁₂ -2,3,3',4,4'-PeCB ⁷	105L	208263-62-1
2,3,3',4,5-PeCB	106	70424-69-0			
2,3,3',4',5-PeCB	107	70424-68-9			
2,3,3',4,5'-PeCB	108	70362-41-3			
2,3,3',4,6-PeCB	109	74472-35-8			
2,3,3',4',6-PeCB	110	38380-03-9			
2,3,3',5,5'-PeCB	111	39635-32-0	¹³ C ₁₂ -2,3,3',5,5'-PeCB ⁵	111 L	235416-29-2
2,3,3',5,6-PeCB	112	74472-36-9			
2,3,3',5',6-PeCB	113	68194-10-5			
2,3,4,4',5-PeCB ⁶	114	74472-37-0	¹³ C ₁₂ -2,3,4,4',5-PeCB ⁷	114 L	208263-63-2
2,3,4,4',6-PeCB	115	74472-38-1			
2,3,4,5,6-PeCB	116	18259-05-7			
2,3,4',5,6-PeCB	117	68194-11-6			
2,3',4,4',5-PeCB ^{3,6}	118	31508-00-6	¹³ C ₁₂ -2,3',4,4',5-PeCB ⁷	118 L	104130-40-7
2,3',4,4',6-PeCB	119	56558-17-9			
2,3',4,5,5'-PeCB	120	68194-12-7			
2,3',4,5',6-PeCB	121	56558-18-0			
2',3,3',4,5-PeCB	122	76842-07-4			
2',3,4,4',5-PeCB ⁶	123	65510-44-3	¹³ C ₁₂ -2',3,4,4',5-PeCB ⁷	123L	208263-64-3
2',3,4,5,5'-PeCB	124	70424-70-3			
2',3,4,5,6'-PeCB	125	74472-39-2			
3,3',4,4',5-PeCB ^{3,6}	126	57465-28-8	¹³ C ₁₂ -3,3',4,4',5-PeCB ^{2,7}	126L	208263-65-4
3,3',4,5,5'-PeCB	127	39635-33-1			
2,2',3,3',4,4'-HxCB ³	128	38380-07-3			
2,2',3,3',4,5-HxCB	129	55215-18-4			
2,2',3,3',4,5'-HxCB	130	52663-66-8			
2,2',3,3',4,6-HxCB	131	61798-70-7			
2,2',3,3',4,6'-HxCB	132	38380-05-1			

CB congener ¹	IUPAC number	CAS registry number	Labeled analog	IUPAC analog	CAS registry number
2,2',3,3',5,5'-HxCB	133	35694-04-3			
2,2',3,3',5,6'-HxCB	134	52704-70-8			
2,2',3,3',5,6'-HxCB	135	52744-13-5			
2,2',3,3',6,6'-HxCB	136	38411-22-2			
2,2',3,4,4',5'-HxCB	137	35694-06-5			
2,2',3,4,4',5'-HxCB ³	138	35065-28-2	¹³ C ₁₂ -2,2',3,4,4',5'-HxCB ⁴	138L	208263-66-5
2,2',3,4,4',6'-HxCB	139	56030-56-9			
2,2',3,4,4',6'-HxCB	140	59291-64-4			
2,2',3,4,5,5'-HxCB	141	52712-04-6			
2,2',3,4,5,6'-HxCB	142	41411-61-4			
2,2',3,4,5,6'-HxCB	143	68194-15-0			
2,2',3,4,5',6'-HxCB	144	68194-14-9			
2,2',3,4,6,6'-HxCB	145	74472-40-5			
2,2',3,4',5,5'-HxCB	146	51908-16-8			
2,2',3,4',5,6'-HxCB	147	68194-13-8			
2,2',3,4',5,6'-HxCB	148	74472-41-6			
2,2',3,4',5',6'-HxCB	149	38380-04-0			
2,2',3,4',6,6'-HxCB	150	68194-08-1			
2,2',3,5,5',6'-HxCB	151	52663-63-5			
2,2',3,5,6,6'-HxCB	152	68194-09-2			
2,2',4,4',5,5'-HxCB ³	153	35065-27-1			
2,2',4,4',5',6'-HxCB	154	60145-22-4			
2,2',4,4',6,6'-HxCB	155	33979-03-2	¹³ C ₁₂ -2,2',4,4',6,6'-HxCB ²	155L	234432-90-7
2,3,3',4,4',5'-HxCB ⁶	156	38380-08-4	¹³ C ₁₂ -2,3,3',4,4',5'-HxCB ⁷	156L	208263-68-7
2,3,3',4,4',5'-HxCB ⁶	157	69782-90-7	¹³ C ₁₂ -2,3,3',4,4',5'-HxCB ⁷	157L	235416-30-5
2,3,3',4,4',6'-HxCB	158	74472-42-7			
2,3,3',4,5,5'-HxCB	159	39635-35-3			
2,3,3',4,5,6'-HxCB	160	41411-62-5			
2,3,3',4,5',6'-HxCB	161	74472-43-8			
2,3,3',4',5,5'-HxCB	162	39635-34-2			
2,3,3',4',5,6'-HxCB	163	74472-44-9			
2,3,3',4',5',6'-HxCB	164	74472-45-0			
2,3,3',5,5',6'-HxCB	165	74472-46-1			
2,3,4,4',5,6'-HxCB	166	41411-63-6			
2,3',4,4',5,5'-HxCB ⁶	167	52663-72-6	¹³ C ₁₂ -2,3',4,4',5,5'-HxCB ⁷	167L	208263-69-8
2,3',4,4',5',6'-HxCB	168	59291-65-5			
3,3',4,4',5,5'-HxCB ^{3,6}	169	32774-16-6	¹³ C ₁₂ -3,3',4,4',5,5'-HxCB ^{2,7}	169L	208263-70-1
2,2',3,3',4,4',5'-HpCB ³	170	35065-30-6			
2,2',3,3',4,4',6'-HpCB	171	52663-71-5			
2,2',3,3',4,5,5'-HpCB	172	52663-74-8			
2,2',3,3',4,5,6'-HpCB	173	68194-16-1			
2,2',3,3',4,5,6'-HpCB	174	38411-25-5			
2,2',3,3',4,5',6'-HpCB	175	40186-70-7			
2,2',3,3',4,6,6'-HpCB	176	52663-65-7			
2,2',3,3',4',5,6'-HpCB	177	52663-70-4			
2,2',3,3',5,5',6'-HpCB	178	52663-67-9	¹³ C ₁₂ -2,2',3,3',5,5',6'-HpCB ⁵	178L	232919-67-4

CB congener ¹	IUPAC number	CAS registry number	Labeled analog	IUPAC analog	CAS registry number
2,2',3,3',5,6,6'-HpCB	179	52663-64-6			
2,2',3,4,4',5,5'-HpCB ³	180	35065-29-3			
2,2',3,4,4',5,6-HpCB	181	74472-47-2			
2,2',3,4,4',5,6'-HpCB	182	60145-23-5			
2,2',3,4,4',5',6-HpCB	183	52663-69-1			
2,2',3,4,4',6,6'-HpCB	184	74472-48-3			
2,2',3,4,5,5',6-HpCB	185	52712-05-7			
2,2',3,4,5,6,6'-HpCB	186	74472-49-4			
2,2',3,4',5,5',6-HpCB ³	187	52663-68-0			
2,2',3,4',5,6,6'-HpCB	188	74487-85-7	¹³ C ₁₂ -2,2',3,4',5,6,6'-HpCB ²	188L	234432-91-8
2,3,3',4,4',5,5'-HpCB ⁶	189	39635-31-9	¹³ C ₁₂ -2,3,3',4,4',5,5'-HpCB ^{2,7}	189L	208263-73-4
2,3,3',4,4',5,6-HpCB	190	41411-64-7			
2,3,3',4,4',5',6-HpCB	191	74472-50-7			
2,3,3',4,5,5',6-HpCB	192	74472-51-8			
2,3,3',4',5,5',6-HpCB	193	69782-91-8			
2,2',3,3',4,4',5,5'-OcCB	194	35694-08-7	¹³ C ₁₂ -2,2',3,3',4,4',5,5'-OcCB ⁴	194L	208263-74-5
2,2',3,3',4,4',5,6-OcCB ³	195	52663-78-2			
2,2',3,3',4,4',5,6'-OcCB	196	42740-50-1			
2,2',3,3',4,4',6,6'-OcCB	197	33091-17-7			
2,2',3,3',4,5,5',6-OcCB	198	68194-17-2			
2,2',3,3',4,5,5',6'-OcCB	199	52663-75-9			
2,2',3,3',4,5,6,6'-OcCB	200	52663-73-7			
2,2',3,3',4,5',6,6'-OcCB	201	40186-71-8			
2,2',3,3',5,5',6,6'-OcCB	202	2136-99-4	¹³ C ₁₂ -2,2',3,3',5,5',6,6'-OcCB ²	202L	105600-26-8
2,2',3,4,4',5,5',6-OcCB	203	52663-76-0			
2,2',3,4,4',5,6,6'-OcCB	204	74472-52-9			
2,3,3',4,4',5,5',6-OcCB	205	74472-53-0	¹³ C ₁₂ -2,3,3',4,4',5,5',6-OcCB ²	205L	234446-64-1
2,2',3,3',4,4',5,5',6-NoCB ³	206	40186-72-9	¹³ C ₁₂ -2,2',3,3',4,4',5,5',6-NoCB ²	206L	208263-75-6
2,2',3,3',4,4',5,6,6'-NoCB	207	52663-79-3			
2,2',3,3',4,5,5',6,6'-NoCB	208	52663-77-1	¹³ C ₁₂ -2,2',3,3',4,5,5',6,6'-NoCB ²	208L	234432-92-9
DeCB ³	209	2051-24-3	¹³ C ₁₂ -DeCB ²	209L	105600-27-9

- Abbreviations for chlorination levels
 - MoCB = monochlorobiphenyl
 - DiCB = dichlorobiphenyl
 - TrCB = trichlorobiphenyl
 - TeCB = tetrachlorobiphenyl
 - PeCB = pentachlorobiphenyl
 - HxCB = hexachlorobiphenyl
 - HpCB = heptachlorobiphenyl
 - OcCB = octachlorobiphenyl
 - NoCB = nonachlorobiphenyl
 - DeCB = decachlorobiphenyl
- Labeled level of chlorination (LOC) window-defining congener
- National Oceanic and Atmospheric Administration (NOAA) congener of interest
- Labeled injection internal standard
- Labeled clean-up standard

6. World Health Organization (WHO) toxic congener
7. Labeled analog of WHO toxic congener

Table 2. Retention times (RT), RT references, relative retention times (RRTs), estimated method detection limits (EMDLs), and estimated minimum levels (EMLs) for the 209 CB congeners on SPB-Octyl.

Cl No. ¹	IUPAC No. ^{2,3}	RT Ref ⁴	RTs ⁵	RRT ⁶	RRT limits ⁷	Window (sec) ⁸	Quantitation reference ⁹	Detection limits and minimum levels - Matrix and concentration ¹⁰				
								Water (pg/L)		Other (ng/kg)		Extract (pg/ μ L)
								EMDL	EML	EMDL	EML	EML
Compounds using 9L (¹³C₁₂-2,5-DiCB) as Labeled injection internal standard												
CB congener												
Monochlorobiphenyls												
1	1	1L	13:44	1.0012	0.9951-1.0073	10	1L	82	200	8	20	10
1	2	3L	16:08	0.9878	0.9847-0.9908	6	1L/3L	4	10	0.4	1	0.5
1	3	3L	16:21	1.0010	0.9980-1.0041	6	3L	88	200	9	20	10
Dichlorobiphenyls												
2	4	4L	16:40	1.0010	0.9960-1.0060	10	4L	172	500	17	50	20
2	10	4L	16:53	1.0140	1.0110-1.0170	6	4L/15L	22	50	2	5	2
2	9	4L	18:55	1.1361	1.1331-1.1391	6	4L/15L	20	50	2	5	2
2	7	4L	19:07	1.1481	1.1451-1.1512	6	4L/15L	15	50	2	5	2
2	6	4L	19:26	1.1672	1.1642-1.1702	6	4L/15L	13	50	1	5	2
2	5	4L	19:48	1.1892	1.1862-1.1922	6	4L/15L	11	50	1	5	2
2	8	4L	19:56	1.1972	1.1942-1.2002	6	4L/15L	121	500	12	50	20
2	14	15L	21:42	0.9267	0.9246-0.9288	6	4L/15L	31	100	3	10	5
2	11	15L	22:42	0.9694	0.9673-0.9715	6	4L/15L	105	200	10	20	10
2	13	15L	23:03	0.9843	0.9822-0.9865	6	4L/15L	28	100	3	10	5
2	12	15L	23:06	0.9865	0.9843-0.9886	6	4L/15L					
2	13/12	15L	23:04	0.9851	0.9829-0.9872	6	4L/15L					
2	15	15L	23:26	1.0007	0.9972-1.0043	10	15L	183	500	18	50	20
Trichlorobiphenyls												
3	19	19L	20:19	1.0008	0.9967-1.0049	10	19L	42	100	4	10	5
3	30	19L	22:15	1.0961	1.0936-1.0985	6	19L/37L	175	500	17	50	20
3	18	19L	22:23	1.1026	1.1002-1.1051	6	19L/37L					
3	30/18	19L	22:19	1.0993	1.0969-1.1018	6	19L/37L					
3	17	19L	22:49	1.1240	1.1215-1.1264	6	19L/37L	86	200	9	20	10
3	27	19L	23:06	1.1379	1.1355-1.1404	6	19L/37L	59	200	6	20	10
3	24	19L	23:14	1.1445	1.1420-1.1470	6	19L/37L	53	200	5	20	10
3	16	19L	23:25	1.1535	1.1511-1.1560	6	19L/37L	35	100	4	10	5
3	32	19L	24:57	1.2291	1.2266-1.2315	6	19L/37L	84	200	8	20	10
3	34	19L	25:17	1.2455	1.2430-1.2479	6	19L/37L	74	200	7	20	10
3	23	19L	25:26	1.2529	1.2504-1.2553	6	19L/37L	50	200	5	20	10

Cl No. ¹	IUPAC No. ^{2,3}	RT Ref ⁴	RTs ⁵	RRT ⁶	RRT limits ⁷	Window (sec) ⁸	Quantitation reference ⁹	Detection limits and minimum levels - Matrix and concentration ¹⁰						
								Water (pg/L)		Other (ng/kg)		Extract (pg/ μ L)		
								EMDL	EML	EMDL	EML	EML		
3	29	19L	25:47	1.2701	1.2660-1.2742	10	19L/37L							
3	26	19L	25:48	1.2709	1.2668-1.2750	10	19L/37L	83	200	8	20	10		
3	26/29	19L	25:48	1.2709	1.2668-1.2750	10	19L/37L							
3	25	37L	26:04	0.8364	0.8348-0.8380	6	19L/37L	55	200	5	20	10		
3	31	37L	26:25	0.8476	0.8460-0.8492	6	19L/37L	152	500	15	50	20		
3	28	37L	26:44	0.8578	0.8551-0.8604	10	19L/37L							
3	20	37L	26:49	0.8604	0.8578-0.8631	10	19L/37L	192	500	19	50	20		
3	28/20	37L	26:47	0.8594	0.8567-0.8620	10	19L/37L							
3	21	37L	26:58	0.8652	0.8626-0.8679	10	19L/37L							
3	33	37L	27:01	0.8668	0.8642-0.8695	10	19L/37L	51	200	5	20	10		
3	21/33	37L	26:59	0.8658	0.8631-0.8684	10	19L/37L							
3	22	37L	27:29	0.8818	0.8802-0.8834	6	19L/37L	90	200	9	20	10		
3	36	37L	29:05	0.9332	0.9316-0.9348	6	19L/37L	79	200	8	20	10		
3	39	37L	29:30	0.9465	0.9449-0.9481	6	19L/37L	85	200	9	20	10		
3	38	37L	30:10	0.9679	0.9663-0.9695	6	19L/37L	83	200	8	20	10		
3	35	37L	30:42	0.9850	0.9834-0.9866	6	19L/37L	77	200	8	20	10		
3	37	37L	31:11	1.0005	0.9989-1.0021	6	37L	132	500	13	50	20		
Labeled Compounds														
1	1L	9L	13:43	0.7257	0.7125-0.7390	30	9L							
1	3L	9L	16:20	0.8642	0.8510-0.8774	30	9L							
2	4L	9L	16:39	0.8810	0.8677-0.8942	30	9L							
2	15L	9L	23:25	1.2390	1.2302-1.2478	20	9L							
3	19L	9L	20:118	1.0741	1.0608-1.0873	30	9L							
3	37L	52L	31:10	1.0803	1.0716-1.0890	30	52L							
Compounds using 52L (¹³C₁₂-2,2',5,5'-TeCB) as Labeled injection internal standard														
CB congener														
Tetrachlorobiphenyls														
4	54	54L	23:51	1.0007	0.9972-1.0042	10	54L	118	500	12	50	20		
4	50	54L	26:07	1.0958	1.0923-1.0993	10	54L/81L/77L							
4	53	54L	26:09	1.0972	1.0937-1.1007	10	54L/81L/77L	58	200	6	20	10		
4	50/53	54L	26:08	1.0965	1.0930-1.1000	10	54L/81L/77L							
4	45	54L	26:55	1.1294	1.1259-1.1329	10	54L/81L/77L							
4	51	54L	26:58	1.1315	1.1280-1.1350	10	54L/81L/77L	51	200	5	20	10		
4	45/51	54L	26:57	1.1308	1.1273-1.1343	10	54L/81L/77L							
4	46	54L	27:18	1.1455	1.1434-1.1476	6	54L/81L/77L	101	200	10	20	10		
4	52	54L	28:45	1.2063	1.2042-1.2084	6	54L/81L/77L	191	500	19	50	20		

CI No. ¹	IUPAC No. ^{2,3}	RT Ref ⁴	RTs ⁵	RRT ⁶	RRT limits ⁷	Window (sec) ⁸	Quantitation reference ⁹	Detection limits and minimum levels - Matrix and concentration ¹⁰				
								Water (pg/L)		Other (ng/kg)		Extract (pg/ μ L)
								EMDL	EML	EMDL	EML	EML
4	73	54L	28:52	1.2112	1.2091-1.2133	6	54L/81L/77L	160	500	16	50	20
4	43	54L	28:58	1.2154	1.2133-1.2175	6	54L/81L/77L	94	200	9	20	10
4	69	54L	29:08	1.2224	1.2189-1.2259	10	54L/81L/77L	115	500	11	50	20
4	49	54L	29:16	1.2280	1.2245-1.2315	10	54L/81L/77L					
4	69/49	54L	29:12	1.2252	1.2217-1.2287	10	54L/81L/77L					
4	48	54L	29:33	1.2399	1.2378-1.2420	6	54L/81L/77L	76	200	8	20	10
4	65	54L	29:49	1.2510	1.2476-1.2545	10	54L/81L/77L	195	500	19	50	20
4	47	54L	29:50	1.2517	1.2483-1.2552	10	54L/81L/77L					
4	44	54L	29:53	1.2538	1.2503-1.2573	10	54L/81L/77L					
4	44/47/65	54L	29:50	1.2517	1.2483-1.2552	10	54L/81L/77L					
4	62	54L	30:06	1.2629	1.2594-1.2664	10	54L/81L/77L	57	200	6	20	10
4	75	54L	30:08	1.2643	1.2608-1.2678	10	54L/81L/77L					
4	59	54L	30:12	1.2671	1.2636-1.2706	10	54L/81L/77L					
4	59/62/75	54L	30:09	1.2650	1.2615-1.2685	10	54L/81L/77L					
4	42	54L	30:26	1.2769	1.2748-1.2790	6	54L/81L/77L	61	200	6	20	10
4	41	54L	30:52	1.2951	1.2916-1.2986	10	54L/81L/77L	119	500	12	50	20
4	71	54L	30:58	1.2993	1.2958-1.3028	10	54L/81L/77L					
4	40	54L	30:01	1.2594	1.2559-1.2629	10	54L/81L/77L					
4	41/40/71	54L	30:58	1.2993	1.2958-1.3028	10	54L/81L/77L					
4	64	54L	31:12	1.3091	1.3070-1.3112	6	54L/81L/77L	70	200	7	20	10
4	72	81L	31:59	0.8336	0.8323-0.8349	6	54L/81L/77L	158	500	16	50	20
4	68	81L	32:18	0.8419	0.8406-0.8432	6	54L/81L/77L	149	500	15	50	20
4	57	81L	32:46	0.8540	0.8527-0.8553	6	54L/81L/77L	125	500	12	50	20
4	58	81L	33:05	0.8623	0.8610-0.8636	6	54L/81L/77L	127	500	13	50	20
4	67	81L	33:13	0.8658	0.8645-0.8671	6	54L/81L/77L	147	500	15	50	20
4	63	81L	33:30	0.8732	0.8719-0.8745	6	54L/81L/77L	138	500	14	50	20
4	61	81L	33:46	0.8801	0.8775-0.8827	12	54L/81L/77L	171	500	17	50	20
4	70	81L	33:53	0.8831	0.8805-0.8858	12	54L/81L/77L					
4	76	81L	33:55	0.8840	0.8814-0.8866	12	54L/81L/77L					
4	74	54L	33:57	0.8849	0.8827-0.8871	10	54L/81L/77L					
4	61/70/74/76	81L	33:55	0.8840	0.8814-0.8866	12	54L/81L/77L					
4	66	81L	34:15	0.8927	0.8914-0.8940	6	54L/81L/77L	162	500	16	50	20
4	55	81L	34:28	0.8983	0.8970-0.8997	6	54L/81L/77L	120	500	12	50	20
4	56	81L	35:03	0.9136	0.9123-0.9149	6	54L/81L/77L	98	200	10	20	10
4	60	81L	35:16	0.9192	0.9179-0.9205	6	54L/81L/77L	131	500	13	50	20
4	80	81L	35:32	0.9262	0.9248-0.9275	6	54L/81L/77L	175	500	18	50	20

Cl No. ¹	IUPAC No. ^{2,3}	RT Ref ⁴	RTs ⁵	RRT ⁶	RRT limits ⁷	Window (sec) ⁸	Quantitation reference ⁹	Detection limits and minimum levels - Matrix and concentration ¹⁰				
								Water (pg/L)		Other (ng/kg)		Extract (pg/ μ L)
								EMDL	EML	EMDL	EML	EML
4	79	81L	37:16	0.9713	0.9700-0.9726	6	54L/81L/77L	173	500	17	50	20
4	78	81L	37:52	0.9870	0.9857-0.9883	6	54L/81L/77L	171	500	17	50	20
4	81	81L	38:23	1.0004	0.9991-1.0017	6	81L	177	500	18	50	20
4	77	77L	39:02	1.0004	0.9991-1.0017	6	77L	169	500	17	50	20
Labeled compounds												
4	54L	52L	23:50	0.8261	0.8203-0.8319	20	52L					
4	81L	52L	38:22	1.3299	1.3241-1.3356	20	52L					
4	77L	52L	39:01	1.3524	1.3466-1.3582	20	52L					
Compounds using 101L (¹³C₁₂-2,2',4,5,5'-PeCB) as Labeled injection internal standard												
CB congener												
Pentachlorobiphenyls												
5	104	104L	29:46	1.0000	0.9972-1.0028	10	104L	228	500	23	50	20
5	96	104L	30:17	1.0174	1.0146-1.0202	10	104L/123L/114L/118L/105L/126L	210	500	21	50	20
5	103	104L	32:11	1.0812	1.0795-1.0829	6	104L/123L/114L/118L/105L/126L	225	500	23	50	20
5	94	104L	32:29	1.0913	1.0896-1.0929	6	104L/123L/114L/118L/105L/126L	121	500	12	50	20
5	95	104L	33:00	1.1086	1.1058-1.1114	10	104L/123L/114L/118L/105L/126L	221	500	22	50	20
5	100	104L	33:06	1.1120	1.1092-1.1148	10	104L/123L/114L/118L/105L/126L					
5	93	104L	33:14	1.1165	1.1137-1.1193	10	104L/123L/114L/118L/105L/126L					
5	102	104L	33:21	1.1204	1.1176-1.1232	10	104L/123L/114L/118L/105L/126L					
5	98	104L	33:26	1.1232	1.1204-1.1260	10	104L/123L/114L/118L/105L/126L					
5	95/100/93/102/98	104L	33:13	1.1159	1.1131-1.1187	15	104L/123L/114L/118L/105L/126L					
5	88	104L	33:48	1.1355	1.1321-1.1389	12	104L/123L/114L/118L/105L/126L	118	500	12	50	20
5	91	104L	33:55	1.1394	1.1366-1.1422	10	104L/123L/114L/118L/105L/126L					
5	88/91	104L	33:52	1.1377	1.1344-1.1411	12	104L/123L/114L/118L/105L/126L					
5	84	104L	34:14	1.1501	1.1484-1.1517	6	104L/123L/114L/118L/105L/126L	124	500	12	50	20
5	89	104L	34:44	1.1669	1.1652-1.1685	6	104L/123L/114L/118L/105L/126L	195	500	19	50	20
5	121	104L	34:57	1.1741	1.1725-1.1758	6	104L/123L/114L/118L/105L/126L	209	500	21	50	20
5	92	123L	35:26	0.8639	0.8627-0.8651	6	104L/123L/114L/118L/105L/126L	115	500	12	50	20
5	113	104L	36:01	0.8781	0.8761-0.8801	10	104L/123L/114L/118L/105L/126L	241	1000	24	100	50
5	90	104L	36:03	0.8789	0.8769-0.8809	10	104L/123L/114L/118L/105L/126L					
5	101	104L	36:04	0.8793	0.8773-0.8813	10	104L/123L/114L/118L/105L/126L					
5	113/90/101	104L	36:03	0.8789	0.8769-0.8809	10	104L/123L/114L/118L/105L/126L					
5	83	104L	36:39	0.8935	0.8911-0.8960	12	104L/123L/114L/118L/105L/126L	217	500	22	50	20
5	99	104L	36:41	0.8944	0.8923-0.8964	10	104L/123L/114L/118L/105L/126L					
5	83/99	104L	36:40	0.8939	0.8915-0.8964	12	104L/123L/114L/118L/105L/126L					

Cl No. ¹	IUPAC No. ^{2,3}	RT Ref ⁴	RTs ⁵	RRT ⁶	RRT limits ⁷	Window (sec) ⁸	Quantitation reference ⁹	Detection limits and minimum levels - Matrix and concentration ¹⁰				
								Water (pg/L)		Other (ng/kg)		Extract (pg/ μ L)
								EMDL	EML	EMDL	EML	EML
5	112	104L	36:51	0.8984	0.8972-0.8996	6	104L/123L/114L/118L/105L/126L	245	1000	25	100	50
5	119	104L	37:12	0.9069	0.9037-0.9102	16	104L/123L/114L/118L/105L/126L	149	500	15	50	20
5	108	104L	37:12	0.9069	0.9037-0.9102	16	104L/123L/114L/118L/105L/126L					
5	86	104L	37:17	0.9090	0.9057-0.9122	16	104L/123L/114L/118L/105L/126L					
5	97	104L	37:17	0.9090	0.9057-0.9122	16	104L/123L/114L/118L/105L/126L					
5	125	104L	37:21	0.9106	0.9074-0.9139	16	104L/123L/114L/118L/105L/126L					
5	87	104L	37:25	0.9122	0.9102-0.9143	10	104L/123L/114L/118L/105L/126L					
5	108/119/86/97/125/87	104L	37:19	0.9098	0.9065-0.9130	16	104L/123L/114L/118L/105L/126L					
5	117	104L	37:57	0.9252	0.9228-0.9277	12	104L/123L/114L/118L/105L/126L	104	200	10	20	10
5	116	104L	38:02	0.9273	0.9248-0.9297	12	104L/123L/114L/118L/105L/126L					
5	85	104L	38:05	0.9285	0.9265-0.9305	10	104L/123L/114L/118L/105L/126L					
5	117/116/85	104L	38:00	0.9265	0.9240-0.9289	12	104L/123L/114L/118L/105L/126L					
5	110	104L	38:16	0.9330	0.9309-0.9350	10	104L/123L/114L/118L/105L/126L	243	1000	24	100	50
5	115	104L	38:18	0.9338	0.9317-0.9358	10	104L/123L/114L/118L/105L/126L					
5	110/115	104L	38:17	0.9334	0.9313-0.9354	10	104L/123L/114L/118L/105L/126L					
5	82	104L	38:40	0.9427	0.9415-0.9439	6	104L/123L/114L/118L/105L/126L	133	500	13	50	20
5	111	104L	38:52	0.9476	0.9464-0.9488	6	104L/123L/114L/118L/105L/126L	243	1000	24	100	50
5	120	104L	39:21	0.9594	0.9581-0.9606	6	104L/123L/114L/118L/105L/126L	147	500	15	50	20
5	107	104L	40:39	0.9911	0.9890-0.9931	10	104L/123L/114L/118L/105L/126L	200	1000	27	100	50
5	124	104L	40:40	0.9915	0.9894-0.9935	10	104L/123L/114L/118L/105L/126L					
5	107/124	104L	40:39	0.9911	0.9890-0.9931	10	104L/123L/114L/118L/105L/126L					
5	109	104L	40:54	0.9972	0.9959-0.9984	6	104L/123L/114L/118L/105L/126L	103	200	10	20	10
5	123	123L	41:02	1.0004	0.9992-1.0016	6	123L	150	500	15	50	20
5	106	123L	41:10	1.0037	1.0024-1.0049	6	104L/123L/114L/118L/105L/126L	143	500	14	50	20
5	118	118L	41:22	1.0004	0.9992-1.0016	6	118L	193	500	19	50	20
5	122	118L	41:49	1.0113	1.0101-1.0125	6	104L/123L/114L/118L/105L/126L	117	500	12	50	20
5	114	114L	41:58	1.0004	0.9992-1.0016	6	114L	120	500	12	50	20
5	105	105L	42:43	0.9996	0.9984-1.0008	6	105L	109	200	11	20	10
5	127	105L	44:09	1.0332	1.0320-1.0343	6	104L/123L/114L/118L/105L/126L	278	1000	28	100	50
5	126	126L	45:58	1.0004	0.9993-1.0015	6	126L	136	500	14	50	20
Labeled compounds												
5	104L	101L	29:46	0.8257	0.8211-0.8303	20	101L					
5	123L	101L	41:01	1.1378	1.1331-1.1424	20	101L					
5	118L	101L	41:21	1.1470	1.1424-1.1516	20	101L					
5	114L	101L	41:57	1.1637	1.1590-1.1683	20	101L					
5	105L	101L	42:44	1.1854	1.1808-1.1900	20	101L					

Cl No. ¹	IUPAC No. ^{2,3}	RT Ref ⁴	RTs ⁵	RRT ⁶	RRT limits ⁷	Window (sec) ⁸	Quantitation reference ⁹	Detection limits and minimum levels - Matrix and concentration ¹⁰				
								Water (pg/L)		Other (ng/kg)		Extract (pg/ μ L)
								EMDL	EML	EMDL	EML	EML
5	126L	101L	45:57	1.2746	1.2700-1.2792	20	101L					
Compounds using 138L (¹³C₁₂-2,2',3,4,4',5'-HxCB) as Labeled injection internal standard												
CB congener												
Hexachlorobiphenyls												
6	155	155L	35:44	1.0000	0.9977-1.0023	10	155L	339	1000	34	100	50
6	152	155L	36:07	1.0107	1.0093-1.0121	6	155L/156L/157L/167L	238	1000	24	100	50
6	150	155L	36:15	1.0145	1.0131-1.0159	6	155L/156L/157L/167L	328	1000	33	100	50
6	136	155L	36:44	1.0280	1.0266-1.0294	6	155L/156L/157L/167L	91	200	9	20	10
6	145	155L	37:00	1.0354	1.0340-1.0368	6	155L/156L/157L/167L	317	1000	32	100	50
6	148	155L	34:26	1.0756	1.0742-1.0770	6	155L/156L/157L/167L	324	1000	32	100	50
6	151	155L	39:10	1.0961	1.0938-1.0984	10	155L/156L/157L/167L	112	500	11	50	20
6	135	155L	39:17	1.0993	1.0970-1.1017	10	155L/156L/157L/167L					
6	154	155L	39:21	1.1012	1.0989-1.1035	10	155L/156L/157L/167L					
6	151/135/154	155L	39:15	1.0984	1.0961-1.1007	10	155L/156L/157L/167L					
6	144	155L	39:47	1.1133	1.1119-1.1147	6	155L/156L/157L/167L	167	500	17	50	20
6	147	155L	40:09	1.1236	1.1213-1.1259	10	155L/156L/157L/167L	179	500	18	50	20
6	149	155L	40:12	1.1250	1.1227-1.1273	10	155L/156L/157L/167L					
6	147/149	155L	40:10	1.1241	1.1217-1.1264	10	155L/156L/157L/167L					
6	134	155L	40:27	1.1320	1.1297-1.1343	10	155L/156L/157L/167L	134	500	13	50	20
6	143	155L	40:30	1.1334	1.1311-1.1357	10	155L/156L/157L/167L					
6	134/143	155L	40:29	1.1329	1.1306-1.1353	10	155L/156L/157L/167L					
6	139	155L	40:47	1.1413	1.1390-1.1437	10	155L/156L/157L/167L	196	500	20	50	20
6	140	155L	40:48	1.1418	1.1395-1.1441	10	155L/156L/157L/167L					
6	139/140	155L	40:47	1.1413	1.1390-1.1437	10	155L/156L/157L/167L					
6	131	155L	41:03	1.1488	1.1474-1.1502	6	155L/156L/157L/167L	121	500	12	50	20
6	142	155L	41:13	1.1535	1.1521-1.1549	6	155L/156L/157L/167L	311	1000	31	100	50
6	132	155L	41:36	1.1642	1.1618-1.1665	10	155L/156L/157L/167L	125	500	12	50	20
6	133	155L	41:57	1.1740	1.1726-1.1754	6	155L/156L/157L/167L	169	500	17	50	20
6	165	167L	42:23	0.8864	0.8853-0.8874	6	155L/156L/157L/167L	361	1000	36	100	50
6	146	167L	42:38	0.8916	0.8906-0.8926	6	155L/156L/157L/167L	182	500	18	50	20
6	161	167L	42:47	0.8947	0.8937-0.8958	6	155L/156L/157L/167L	352	1000	35	100	50
6	153	167L	43:17	0.9052	0.9035-0.9069	10	155L/156L/157L/167L	130	500	13	50	20
6	168	167L	43:21	0.9066	0.9048-0.9083	10	155L/156L/157L/167L					
6	153/168	167L	43:19	0.9059	0.9041-0.9076	10	155L/156L/157L/167L					
6	141	167L	43:34	0.9111	0.9101-0.9122	6	155L/156L/157L/167L	93	200	9	20	10
6	130	167L	44:01	0.9205	0.9195-0.9216	6	155L/156L/157L/167L	136	500	14	50	20

Cl No. ¹	IUPAC No. ^{2,3}	RT Ref ⁴	RTs ⁵	RRT ⁶	RRT limits ⁷	Window (sec) ⁸	Quantitation reference ⁹	Detection limits and minimum levels - Matrix and concentration ¹⁰				
								Water (pg/L)		Other (ng/kg)		Extract (pg/ μ L)
								EMDL	EML	EMDL	EML	EML
6	137	167L	44:14	0.9251	0.9240-0.9261	6	155L/156L/157L/167L	300	1000	30	100	50
6	164	167L	44:22	0.9278	0.9268-0.9289	6	155L/156L/157L/167L	136	500	14	50	20
6	138	167L	44:42	0.9348	0.9324-0.9373	14	155L/156L/157L/167L	211	500	21	50	20
6	163	167L	44:42	0.9348	0.9324-0.9373	14	155L/156L/157L/167L					
6	129	167L	44:47	0.9366	0.9341-0.9390	14	155L/156L/157L/167L					
6	160	167L	44:53	0.9387	0.9369-0.9404	10	155L/156L/157L/167L					
6	138/163/129/160	167L	44:47	0.9366	0.9341-0.9390	14	155L/156L/157L/167L					
6	158	167L	45:05	0.9428	0.9418-0.9439	6	155L/156L/157L/167L	96	200	10	20	10
6	166	167L	45:59	0.9617	0.9599-0.9634	10	155L/156L/157L/167L	124	500	12	50	20
6	128	167L	46:46	0.9651	0.9634-0.9669	10	155L/156L/157L/167L					
6	128/166	167L	46:04	0.9634	0.9617-0.9651	10	155L/156L/157L/167L					
6	159	167L	46:59	0.9826	0.9815-0.9836	6	155L/156L/157L/167L	348	1000	35	100	50
6	162	167L	47:18	0.9892	0.9881-0.9902	6	155L/156L/157L/167L	355	1000	35	100	50
6	167	167L	47:49	1.0000	0.9990-1.0010	6	155L/156L/157L/167L	115	500	11	50	20
6	156	156L/157L	49:05	0.9993	0.9983-1.0003	6	156L/157L	132	500	13	50	20
6	157	156L/157L	49:09	1.0007	0.9990-1.0024	10	156L/157L					
6	156/157	156L/157L	45:07	1.0000	0.9990-1.0010	6	156L/157L					
6	169	169L	52:31	0.9949	0.9940-0.9959	6	169L	161	500	16	50	20
Labeled compounds												
6	155L	138L	35:44	0.7997	0.7960-0.8034	20	138L					
6	167L	138L	47:49	1.0701	1.0664-1.0739	20	138L					
6	156L	138L	49:05	1.0985	1.0974-1.0996	6	138L					
6	157L	138L	49:08	1.0996	1.0959-1.1033	20	138L					
6	156L/157L	138L	49:07	1.0992	1.0981-1.1003	6	138L					
6	169L	138L	52:30	1.1749	1.1738-1.1761	6	138L					
Compounds using 194L(¹³C₁₂-2,2',3,3',4,4',5,5'-O₂CB) as Labeled injection internal standard												
CB congener												
Heptachlorobiphenyls												
7	188	188L	41:51	1.0000	0.9988-1.0012	6	188L	235	500	23	50	20
7	179	188L	42:19	1.0112	1.0100-1.0123	6	188L/189L	229	500	23	50	20
7	184	188L	42:45	1.0215	1.0203-1.0227	6	188L/189L	403	1000	40	100	50
7	176	188L	43:15	1.0335	1.0323-1.0346	6	188L/189L	385	1000	39	100	50
7	186	188L	43:45	1.0454	1.0442-1.0466	6	188L/189L	407	1000	41	100	50
7	178	188L	45:06	1.0777	1.0765-1.0789	6	188L/189L	221	500	22	50	20
7	175	188L	45:46	1.0936	1.0924-1.0948	6	188L/189L	383	1000	38	100	50
7	187	188L	46:02	1.1000	1.0988-1.1012	6	188L/189L	191	500	19	50	20

Cl No. ¹	IUPAC No. ^{2,3}	RT Ref ⁴	RTs ⁵	RRT ⁶	RRT limits ⁷	Window (sec) ⁸	Quantitation reference ⁹	Detection limits and minimum levels - Matrix and concentration ¹⁰				
								Water (pg/L)		Other (ng/kg)		Extract (pg/μL)
								EMDL	EML	EMDL	EML	EML
7	182	188L	46:14	1.1047	1.1035-1.1059	6	188L/189L	398	1000	40	100	50
7	183	188L	46:42	1.1159	1.1147-1.1171	6	188L/189L	401	1000	40	100	50
7	185	188L	46:53	1.1203	1.1191-1.1215	6	188L/189L					
7	183/185	188L	46:47	1.1179	1.1167-1.1191	6	188L/189L					
7	174	188L	47:02	1.1239	1.1227-1.1251	6	188L/189L					
7	177	188L	47:30	1.1350	1.1338-1.1362	6	188L/189L	141	500	14	50	20
7	181	188L	47:52	1.1438	1.1426-1.1450	6	188L/189L	396	1000	40	100	50
7	171	188L	48:10	1.1509	1.1489-1.1529	10	188L/189L	374	1000	37	100	50
7	173	188L	48:11	1.1513	1.1501-1.1525	6	188L/189L					
7	171/173	188L	48:10	1.1509	1.1489-1.1529	10	188L/189L					
7	172	189L	49:47	0.9035	0.9026-0.9044	6	188L/189L					
7	192	189L	50:06	0.9093	0.9083-0.9102	6	188L/189L	420	1000	42	100	50
7	193	189L	50:26	0.9153	0.9144-0.9162	6	188L/189L	136	500	14	50	20
7	180	189L	50:27	0.9156	0.9147-0.9165	6	188L/189L					
7	180/193	189L	50:26	0.9153	0.9144-0.9162	6	188L/189L					
7	191	189L	50:51	0.9229	0.9220-0.9238	6	188L/189L					
7	170	189L	51:54	0.9419	0.9410-0.9428	6	188L/189L	162	500	16	50	20
7	190	189L	52:26	0.9516	0.9507-0.9525	6	188L/189L	234	500	23	50	20
7	189	189L	55:07	1.0003	0.9994-1.0012	6	189L	177	500	18	50	20
Octachlorobiphenyls												
8	202	202L	47:32	1.0004	0.9986-1.0021	10	202L	442	1000	44	100	50
8	201	202L	48:31	1.0210	1.0193-1.0228	10	202L/205L	440	1000	44	100	50
8	204	202L	49:11	1.0351	1.0340-1.0361	6	202L/205L	447	1000	45	100	50
8	197	202L	49:27	1.0407	1.0396-1.0417	6	202L/205L	245	1000	25	100	50
8	200	202L	49:40	1.0452	1.0442-1.0463	6	202L/205L					
8	197/200	202L	49:33	1.0428	1.0417-1.0438	6	202L/205L					
8	198	202L	52:30	1.1049	1.1031-1.1066	10	202L/205L					
8	199	202L	52:32	1.1056	1.1045-1.1066	6	202L/205L	203	500	20	50	25
8	198/199	202L	52:31	1.1052	1.1035-1.1070	10	202L/205L	429	1000	43	100	50
8	196	205L	53:13	0.9207	0.9198-0.9216	6	202L/205L					
8	203	205L	53:26	0.9245	0.9236-0.9253	6	202L/205L					
8	195	205L	54:55	0.9501	0.9493-0.9510	6	202L/205L					
8	194	205L	57:19	0.9916	0.9908-0.9925	6	202L/205L	170	500	17	50	20
8	205	205L	57:49	1.0003	0.9994-1.0012	6	205L	449	1000	45	100	50
Nonachlorobiphenyls												
9	208	208L	54:33	1.0003	0.9994-1.0012	6	208L	455	1000	46	100	50

Cl No. ¹	IUPAC No. ^{2,3}	RT Ref ⁴	RTs ⁵	RRT ⁶	RRT limits ⁷	Window (sec) ⁸	Quantitation reference ⁹	Detection limits and minimum levels - Matrix and concentration ¹⁰				
								Water (pg/L)		Other (ng/kg)		Extract (pg/ μ L)
								EMDL	EML	EMDL	EML	EML
9	207	208L	55:32	1.0183	1.0174-1.0193	6	208L/206L	453	1000	45	100	50
9	206	206L	59:37	1.0003	0.9994-1.0011	6	206L	451	1000	45	100	50
Decachlorobiphenyl												
10	209	209L	61:15	1.0003	0.9995-1.0011	6	209L	153	500	15	50	20
Labeled compounds												
7	188L	194L	41:51	0.7304	0.7275-0.7333	20	194L					
7	180L	194L	50:27	0.8805	0.8775-0.8834	20	194L					
7	170L	194L	51:53	0.9055	0.9026-0.9084	20	194L					
7	189L	194L	55:06	0.9616	0.9587-0.9645	20	194L					
8	202L	194L	47:31	0.8293	0.8264-0.8322	20	194L					
8	205L	194L	57:48	1.0087	1.0044-1.0131	30	194L					
9	208L	194L	54:32	0.9517	0.9488-0.9546	20	194L					
9	206L	194L	59:36	1.0401	1.0358-1.0445	30	194L					
10	209L	194L	61:14	1.0686	1.0643-1.0730	30	194L					

Labeled clean-up standards												
3	28L	52L	26:44	0.9266	0.9209-0.9324	20	52L					
5	111L	101L	38:51	1.0777	1.0730-1.0823	20	101L					
7	178L	138L	45:05	1.0090	1.0052-1.0127	20	138L					
Labeled injection internal standards												
2	9L	138L	18:54	0.4648	0.4596-0.4699	25	178L					
4	52L	138L	28:51	0.7094	0.7043-0.7145	25	178L					
5	101L	138L	36:03	0.8865	0.8814-0.8916	25	178L					
6	138L	138L	44:41	1.0988	1.0783-1.1193	100	178L					
8	194L	138L	57:18	1.4090	1.4039-1.4141	25	178L					

- Number of chlorines on congener.
- Suffix "L" indicates labeled compound.
- Multiple congeners in a box indicates a group of congeners that co-elute or may not be adequately resolved on a 30-m SPB-Octyl column. Congeners included in the group are listed as the last entry in the box.
- Retention time reference that is used to locate target congener.
- Retention time of target congener.
- RRT between the RT for the congener and RT for the reference.
- Nominal limits based on an $\pm 0.5\%$ of the RRT, adjusted for the nearest eluted isomer.
- RT window width for congener or group of two or more congeners.

9. Labeled congeners that form the quantitation reference. Areas from the exact m/z 's of the congeners listed in the quantitation reference are summed, and divided by the number of congeners in the quantitation reference. For example, for congener 10, the areas at the exact m/z 's for 4L and 15L are summed and the sum is divided by 2 (because there are 2 congeners in the quantitation reference).
10. EMDLs and EMLs with common laboratory interferences present. Without interferences, EMDLs and EMLs will be, respectively, 5 and 10 pg/L for aqueous samples, 0.5 and 1.0 ng/kg for soil, tissue, and mixed-phase samples, and EMLs for extracts will be 0.5 pg/uL.

Table 3. Concentrations of native and labeled chlorinated biphenyls in stock solutions, spiking solutions, and final extracts

CB congener	Solution concentrations		
	Stock ($\mu\text{g/mL}$)	Spiking (ng/mL)	Extract (ng/mL)
Native Toxics/LOC¹			
1	20	1.0	50
3	20	1.0	50
4	20	1.0	50
15	20	1.0	50
19	20	1.0	50
37	20	1.0	50
54	20	1.0	50
77	20	1.0	50
81	20	1.0	50
104	20	1.0	50
105	20	1.0	50
114	20	1.0	50
118	20	1.0	50
123	20	1.0	50
126	20	1.0	50
155	20	1.0	50
156	20	1.0	50
157	20	1.0	50
167	20	1.0	50
169	20	1.0	50
188	20	1.0	50
189	20	1.0	50
202	20	1.0	50
205	20	1.0	50
206	20	1.0	50
208	20	1.0	50
209	20	1.0	50
Native congener mix stock solutions²			
MoCB thru TrCB	2.5		
TeCB thru HpCB	5.0		
OcCB thru DeCB	7.5		
Labeled Toxics/LOC/window-defining³			
1L	1.0	2.0	100
3L	1.0	2.0	100
4L	1.0	2.0	100

CB congener	Solution concentrations		
	Stock ($\mu\text{g/mL}$)	Spiking (ng/mL)	Extract (ng/mL)
15L	1.0	2.0	100
19L	1.0	2.0	100
37L	1.0	2.0	100
54L	1.0	2.0	100
77L	1.0	2.0	100
81L	1.0	2.0	100
104L	1.0	2.0	100
105L	1.0	2.0	100
114L	1.0	2.0	100
118L	1.0	2.0	100
123L	1.0	2.0	100
126L	1.0	2.0	100
155L	1.0	2.0	100
156L	1.0	2.0	100
157L	1.0	2.0	100
167L	1.0	2.0	100
169L	1.0	2.0	100
188L	1.0	2.0	100
189L	1.0	2.0	100
202L	1.0	2.0	100
205L	1.0	2.0	100
206L	1.0	2.0	100
208L	1.0	2.0	100
209L	1.0	2.0	100
Labeled clean-up⁴			
28L	1.0	2.0	100
111L	1.0	2.0	100
178L	1.0	2.0	100
Labeled injection internal⁵			
9L	5.0	1000	100
52L	5.0	1000	100
101L	5.0	1000	100
138L	5.0	1000	100
194L	5.0	1000	100

Diluted combined 209 congener⁶		
Standard	Solution concentration ($\mu\text{g/mL}$)	
	Native	Labeled
Native congeners		
MoCB thru TrCB	50	
TeCB thru HpCB	100	
OcCB thru DeCB	150	
Labeled Toxics/LOC/window-defining		100
Labeled Cleanup		100
Labeled Injection internal		100

1. Stock solution: Section 7.8.1; Spiking solution: Section 7.11
2. Section 7.8.1.2
3. Stock solution: Section 7.9.1; Spiking solution: Section 7.12
4. Stock solution: Section 7.9.2; Spiking solution: Section 7.13
5. Stock solution: Section 7.9.3; Spiking solution: Section 7.14
6. Section 7.10.2.2.2

Table 4. Composition of individual native CB congener solutions¹

Solution identifier				
A2	B2	C2	D2	E2
Accu-Standard part number				
M-1668A-1	M-1668A-2	M-1668A-3	M-1668A-4	M-1668A-5
2	7	13	25	1
10	5	17	21	3
9	12	29	69	4
6	18	20	47	15
8	24	46	42	19
14	23	65	64	16
11	28	59	70	37
30	22	40	102	54
27	39	67	97	43
32	53	76	115	44
34	51	80	123	74
26	73	93	134	56
31	48	84	131	77
33	62	101	163	104
36	71	112	180	98
38	68	86		125
35	58	116		110
50	61	109/107		126
45	55	154		155
52	60	147		138
49	94	140		169
75	100	146		188
41	91	141		189
72	121	164		202
57	90	158		205
63	99	182		208
66	108/109	174		206
79	117	173		209
78	111	193		
81	107/108			
96	118			
103	114			
95	150			
88	145			
89	135			
92	149			
113	139			
83	132			
119	165			
87	168			

Solution identifier				
A2	B2	C2	D2	E2
Accu-Standard part number				
M-1668A-1	M-1668A-2	M-1668A-3	M-1668A-4	M-1668A-5
85	137			
82	160			
120	128			
124	162			
106	157			
122	184			
105	186			
127	187			
152	185			
136	181			
148	192			
151	197			
144	199/201			
143	203			
142				
133				
161				
153				
130				
129				
166				
159				
167				
156				
179				
176				
178				
175				
183				
177				
171				
172				
191				
170				
190				
201/200				
204				
200/199				
198				
196				
195				
194				

Solution identifier				
A2	B2	C2	D2	E2
Accu-Standard part number				
M-1668A-1	M-1668A-2	M-1668A-3	M-1668A-4	M-1668A-5
207				
Totals				
83	54	29	15	28

1. Congeners present in each standard listed in elution order for each level of chlorination. IUPAC number listed first; BZ number listed second where ambiguous. See Table 3 for concentrations of congeners in stock solutions and Table 5 for concentrations in calibration standard.

Table 5. Concentration of CB congeners in calibration and calibration verification standards

CB congener	IUPAC ¹	Solution concentration (ng/mL)					
		CS-0.2 (Hi sens) ²	CS-1	CS-2	CS-3 (VER)	CS-4	CS-5
Native Toxics/LOC							
2-MoCB	1	0.2	1.0	5.0	50	400	2000
4-MoCB	3	0.2	1.0	5.0	50	400	2000
2,2'-DiCB	4	0.2	1.0	5.0	50	400	2000
4,4'-DiCB	15	0.2	1.0	5.0	50	400	2000
2,2',6'-TrCB	19	0.2	1.0	5.0	50	400	2000
3,4,4'-TrCB	37	0.2	1.0	5.0	50	400	2000
2,2',6,6'-TeCB	54	0.2	1.0	5.0	50	400	2000
3,3',4,4'-TeCB	77	0.2	1.0	5.0	50	400	2000
3,4,4',5'-TeCB	81	0.2	1.0	5.0	50	400	2000
2,2',4,6,6'-PeCB	104	0.2	1.0	5.0	50	400	2000
2,3,3',4,4'-PeCB	105	0.2	1.0	5.0	50	400	2000
2,3,4,4',5'-PeCB	114	0.2	1.0	5.0	50	400	2000
2,3',4,4',5'-PeCB	118	0.2	1.0	5.0	50	400	2000
2',3,4,4',5'-PeCB	123	0.2	1.0	5.0	50	400	2000
3,3',4,4',5'-PeCB	126	0.2	1.0	5.0	50	400	2000
2,2',4,4',6,6'-HxCB	155	0.2	1.0	5.0	50	400	2000
2,3,3',4,4',5'-HxCB	156	0.2	1.0	5.0	50	400	2000
2,3,3',4,4',5'-HxCB	157	0.2	1.0	5.0	50	400	2000
2,3',4,4',5,5'-HxCB	167	0.2	1.0	5.0	50	400	2000
3,3',4,4',5,5'-HxCB	169	0.2	1.0	5.0	50	400	2000
2,2',3,4',5,6,6'-HpCB	188	0.2	1.0	5.0	50	400	2000
2,3,3',4,4',5,5'-HpCB	189	0.2	1.0	5.0	50	400	2000
2,2',3,3',5,5',6,6'-OcCB	202	0.2	1.0	5.0	50	400	2000
2,3,3',4,4',5,5',6'-OcCB	205	0.2	1.0	5.0	50	400	2000
2,2',3,3',4,4',5,5',6'-NoCB	206	0.2	1.0	5.0	50	400	2000
2,2',3,3',4',5,5',6,6'-NoCB	208	0.2	1.0	5.0	50	400	2000
DeCB	209	0.2	1.0	5.0	50	400	2000
Labeled Toxics/LOC/window-defining							
¹³ C ₁₂ -2-MoCB	1L	100	100	100	100	100	100
¹³ C ₁₂ -4-MoCB	3L	100	100	100	100	100	100
¹³ C ₁₂ -2,2'-DiCB	4L	100	100	100	100	100	100
¹³ C ₁₂ -4,4'-DiCB	15L	100	100	100	100	100	100
¹³ C ₁₂ -2,2',6'-TrCB	19L	100	100	100	100	100	100
¹³ C ₁₂ -3,4,4'-TrCB	37L	100	100	100	100	100	100
¹³ C ₁₂ -2,2',6,6'-TeCB	54L	100	100	100	100	100	100
¹³ C ₁₂ -3,3',4,4'-TeCB	77L	100	100	100	100	100	100
¹³ C ₁₂ -3,4,4',5'-TeCB	81L	100	100	100	100	100	100
¹³ C ₁₂ -2,2',4,6,6'-PeCB	104L	100	100	100	100	100	100
¹³ C ₁₂ -2,3,3',4,4'-PeCB	105L	100	100	100	100	100	100
¹³ C ₁₂ -2,3,4,4',5'-PeCB	114L	100	100	100	100	100	100
¹³ C ₁₂ -2,3',4,4',5'-PeCB	118L	100	100	100	100	100	100
¹³ C ₁₂ -2',3,4,4',5'-PeCB	123L	100	100	100	100	100	100
¹³ C ₁₂ -3,3',4,4',5'-PeCB	126L	100	100	100	100	100	100

Method 1668, Revision A

CB congener	IUPAC ¹	Solution concentration (ng/mL)					
		CS-0.2 (Hi sens) ²	CS-1	CS-2	CS-3 (VER)	CS-4	CS-5
¹³ C ₁₂ -2,2',4,4',6,6'-HxCB	155L	100	100	100	100	100	100
¹³ C ₁₂ -2,3,3',4,4',5-HxCB	156L	100	100	100	100	100	100
¹³ C ₁₂ -2,3,3',4,4',5'-HxCB	157L	100	100	100	100	100	100
¹³ C ₁₂ -2,3',4,4',5,5'-HxCB	167L	100	100	100	100	100	100
¹³ C ₁₂ -3,3',4,4',5,5'-HxCB	169L	100	100	100	100	100	100
¹³ C ₁₂ -2,2',3,4',5,6,6'-HpCB	188L	100	100	100	100	100	100
¹³ C ₁₂ -2,3,3',4,4',5,5'-HpCB	189L	100	100	100	100	100	100
¹³ C ₁₂ -2,2',3,3',5,5',6,6'-OcCB	202L	100	100	100	100	100	100
¹³ C ₁₂ -2,3,3',4,4',5,5',6-OcCB	205L	100	100	100	100	100	100
¹³ C ₁₂ -2,2',3,3',4,4',5,5',6-NoCB	206L	100	100	100	100	100	100
¹³ C ₁₂ -2,2',3,3',4,4',5,5',6,6'-NoCB	208L	100	100	100	100	100	100
¹³ C ₁₂ -DeCB	209L	100	100	100	100	100	100
Labeled clean-up							
¹³ C ₁₂ -2,4,4'-TrCB	28L	100	100	100	100	100	100
¹³ C ₁₂ -2,3,3',5,5'-PeCB	111L	100	100	100	100	100	100
¹³ C ₁₂ -2,2',3,3',5,5',6-HpCB	178L	100	100	100	100	100	100
Labeled injection internal							
¹³ C ₁₂ -2,5-DiCB	9L	100	100	100	100	100	100
¹³ C ₁₂ -2,2',5,5'-TeCB	52L	100	100	100	100	100	100
¹³ C ₁₂ -2,2',4',5,5'-PeCB	101L	100	100	100	100	100	100
¹³ C ₁₂ -2,2',3',4,4',5'-HxCB	138L	100	100	100	100	100	100
¹³ C ₁₂ -2,2',3,3',4,4',5,5'-OcCB	194L	100	100	100	100	100	100

1. Suffix "L" indicates labeled compound
2. Additional concentration used for calibration of high sensitivity HRGC/HRMS systems

Table 6. QC acceptance criteria for chlorinated biphenyls in VER, IPR, OPR, and samples¹

Congener	IUPAC number ²	Test conc (ng/mL) ³	VER ⁴ (%)	IPR		OPR (%)	Labeled compound recovery in samples (%)
				RSD (%)	X (%)		
2-MoCB	1	50	70-130	40	60-140	50-150	
4-MoCB	3	50	70-130	40	60-140	50-150	
2,2'-DiCB	4	50	70-130	40	60-140	50-150	
4,4'-DiCB	15	50	70-130	40	60-140	50-150	
2,2',6-TrCB	19	50	70-130	40	60-140	50-150	
3,4,4'-TrCB	37	50	70-130	40	60-140	50-150	
2,2',6,6'-TeCB	54	50	70-130	40	60-140	50-150	
3,3',4,4'-TeCB	77	50	70-130	40	60-140	50-150	
3,4,4',5-TeCB	81	50	70-130	40	60-140	50-150	
2,2',4,6,6'-PeCB	104	50	70-130	40	60-140	50-150	
2,3,3',4,4'-PeCB	105	50	70-130	40	60-140	50-150	
2,3,4,4',5-PeCB	114	50	70-130	40	60-140	50-150	
2,3',4,4',5-PeCB	118	50	70-130	40	60-140	50-150	
2',3,4,4',5-PeCB	123	50	70-130	40	60-140	50-150	
3,3',4,4',5-PeCB	126	50	70-130	40	60-140	50-150	
2,2',4,4',6,6'-HxCB	155	50	70-130	40	60-140	50-150	
2,3,3',4,4',5-HxCB ⁵	156	50	70-130	40	60-140	50-150	
2,3,3',4,4',5'-HxCB ⁵	157	50	70-130	40	60-140	50-150	
2,3',4,4',5,5'-HxCB	167	50	70-130	40	60-140	50-150	
3,3',4,4',5,5'-HxCB	169	50	70-130	40	60-140	50-150	
2,2',3,4',5,6,6'-HpCB	188	50	70-130	40	60-140	50-150	
2,3,3',4,4',5,5'-HpCB	189	50	70-130	40	60-140	50-150	
2,2',3,3',5,5',6,6'-OcCB	202	50	70-130	40	60-140	50-150	
2,3,3',4,4',5,5',6-OcCB	205	50	70-130	40	60-140	50-150	
2,2',3,3',4,4',5,5',6-NoCB	206	50	70-130	40	60-140	50-150	
2,2',3,3',4,5,5',6,6'-NoCB	208	50	70-130	40	60-140	50-150	
DeCB	209	50	70-130	40	60-140	50-150	
¹³ C ₁₂ -2-MoCB	1L	100	50-150	50	35-135	30-140	25-150
¹³ C ₁₂ -4-MoCB	3L	100	50-150	50	35-135	30-140	25-150
¹³ C ₁₂ -2,2'-DiCB	4L	100	50-150	50	35-135	30-140	25-150
¹³ C ₁₂ -4,4'-DiCB	15L	100	50-150	50	35-135	30-140	25-150
¹³ C ₁₂ -2,2',6-TrCB	19L	100	50-150	50	35-135	30-140	25-150
¹³ C ₁₂ -3,4,4'-TrCB	37L	100	50-150	50	35-135	30-140	25-150
¹³ C ₁₂ -2,2',6,6'-TeCB	54L	100	50-150	50	35-135	30-140	25-150
¹³ C ₁₂ -3,3',4,4'-TCB	77L	100	50-150	50	35-135	30-140	25-150
¹³ C ₁₂ -3,4,4',5-TeCB	81L	100	50-150	50	35-135	30-140	25-150

Congener	IUPAC number ²	Test conc (ng/mL) ³	VER ⁴ (%)	IPR		OPR (%)	Labeled compound recovery in samples (%)
				RSD (%)	X (%)		
¹³ C ₁₂ -2,2',4,6,6'-PeCB	104L	100	50-150	50	35-135	30-140	25-150
¹³ C ₁₂ -2,3,3',4,4'-PeCB	105L	100	50-150	50	35-135	30-140	25-150
¹³ C ₁₂ -2,3,4,4',5-PeCB	114L	100	50-150	50	35-135	30-140	25-150
¹³ C ₁₂ -2,3',4,4',5-PeCB	118L	100	50-150	50	35-135	30-140	25-150
¹³ C ₁₂ -2',3,4,4',5-PeCB	123L	100	50-150	50	35-135	30-140	25-150
¹³ C ₁₂ -3,3',4,4',5-PeCB	126L	100	50-150	50	35-135	30-140	25-150
¹³ C ₁₂ -2,2',4,4',6,6'-HxCB	155L	100	50-150	50	35-135	30-140	25-150
¹³ C ₁₂ -2,3,3',4,4',5-HxCB ⁵	156L	100	50-150	50	35-135	30-140	25-150
¹³ C ₁₂ -2,3,3',4,4',5'-HxCB ⁵	157L	100	50-150	50	35-135	30-140	25-150
¹³ C ₁₂ -2,3',4,4',5,5'-HxCB	167L	100	50-150	50	35-135	30-140	25-150
¹³ C ₁₂ -3,3',4,4',5,5'-HxCB	169L	100	50-150	50	35-135	30-140	25-150
¹³ C ₁₂ -2,2',3,4',5,6,6'-HpCB	188L	100	50-150	50	35-135	30-140	25-150
¹³ C ₁₂ -2',3,3',4,4',5,5'-HpCB	189L	100	50-150	50	35-135	30-140	25-150
¹³ C ₁₂ -2,2',3,3',5,5',6,6'-OcCB	202L	100	50-150	50	35-135	30-140	25-150
¹³ C ₁₂ -2,3,3',4,4',5,5',6-OcCB	205L	100	50-150	50	35-135	30-140	25-150
¹³ C ₁₂ -2,2',3,3',4,4',5,5',6-NoCB	206L	100	50-150	50	35-135	30-140	25-150
¹³ C ₁₂ -2,2',3,3',4,5,5',6,6'-NoCB	208L	100	50-150	50	35-135	30-140	25-150
¹³ C ₁₂ -2,2',3,3',4,4',5,5',6,6'-DeCB	209L	100	50-150	50	35-135	30-140	25-150
Cleanup standard							
¹³ C ₁₂ -2,4,4'-TrCB	28L	100	60-130	45	45-120	40-125	30-135
¹³ C ₁₂ -2,3,3',5,5'-PeCB	111L	100	60-130	45	45-120	40-125	30-135
¹³ C ₁₂ -2,2',3,3',5,5',6-HpCB	178L	100	60-130	45	45-120	40-125	30-135

1. QC acceptance criteria for IPR, OPR, and samples based on a 20 μ L extract final volume
2. Suffix "L" indicates labeled compound.
3. See Table 5.
4. Section 15.3.
5. PCBs 156 and 157 are tested as the sum of two concentrations

Table 7. Scan descriptors, levels of chlorination, m/z information, and substances monitored by HRGC/HRMS

Function and chlorine level	m/z	m/z type	m/z formula	Substance
Fn-1; Cl-1	188.0393	M	$^{12}\text{C}_{12}\text{H}_9\text{ }^{35}\text{Cl}$	Cl-1 CB
	190.0363	M+2	$^{12}\text{C}_{12}\text{H}_9\text{ }^{37}\text{Cl}$	Cl-1 CB
	200.0795	M	$^{13}\text{C}_{12}\text{H}_9\text{ }^{35}\text{Cl}$	$^{13}\text{C}_{12}$ Cl-1 CB
	202.0766	M+2	$^{13}\text{C}_{12}\text{H}_9\text{ }^{37}\text{Cl}$	$^{13}\text{C}_{12}$ Cl-1 CB
	218.9856	lock	C_4F_9	PFK
Fn-2; Cl-2,3	222.0003	M	$^{12}\text{C}_{12}\text{H}_8\text{ }^{35}\text{Cl}_2$	Cl-2 PCB
	223.9974	M+2	$^{12}\text{C}_{12}\text{H}_8\text{ }^{35}\text{Cl}\text{ }^{37}\text{Cl}$	Cl-2 PCB
	225.9944	M+4	$^{12}\text{C}_{12}\text{H}_8\text{ }^{37}\text{Cl}_2$	Cl-2 PCB
	234.0406	M	$^{13}\text{C}_{12}\text{H}_8\text{ }^{35}\text{Cl}_2$	$^{13}\text{C}_{12}$ Cl-2 PCB
	236.0376	M+2	$^{13}\text{C}_{12}\text{H}_8\text{ }^{35}\text{Cl}\text{ }^{37}\text{Cl}$	$^{13}\text{C}_{12}$ Cl-2 PCB
	242.9856	lock	C_6F_9	PFK
	255.9613	M	$^{12}\text{C}_{12}\text{H}_7\text{ }^{35}\text{Cl}_3$	Cl-3 PCB
	257.9584	M+2	$^{12}\text{C}_{12}\text{H}_7\text{ }^{35}\text{Cl}_2\text{ }^{37}\text{Cl}$	Cl-3 PCB
Fn-3	255.9613	M	$^{12}\text{C}_{12}\text{H}_7\text{ }^{35}\text{Cl}_3$	Cl-3 PCB
Cl-3,4,5	257.9584	M+2	$^{12}\text{C}_{12}\text{H}_7\text{ }^{35}\text{Cl}_2\text{ }^{37}\text{Cl}$	Cl-3 PCB
	259.9554	M+4	$^{12}\text{C}_{12}\text{H}_7\text{ }^{35}\text{Cl}\text{ }^{37}\text{Cl}_2$	Cl-3 PCB
	268.0016	M	$^{13}\text{C}_{12}\text{H}_7\text{ }^{35}\text{Cl}_3$	$^{13}\text{C}_{12}$ Cl-3 PCB
	269.9986	M+2	$^{13}\text{C}_{12}\text{H}_7\text{ }^{35}\text{Cl}_2\text{ }^{37}\text{Cl}$	$^{13}\text{C}_{12}$ Cl-3 PCB
	280.9825	lock	C_6F_{11}	PFK
	289.9224	M	$^{12}\text{C}_{12}\text{H}_6\text{ }^{35}\text{Cl}_4$	Cl-4 PCB
	291.9194	M+2	$^{12}\text{C}_{12}\text{H}_6\text{ }^{35}\text{Cl}_3\text{ }^{37}\text{Cl}$	Cl-4 PCB
	293.9165	M+4	$^{12}\text{C}_{12}\text{H}_6\text{ }^{35}\text{Cl}_2\text{ }^{37}\text{Cl}_2$	Cl-4 PCB

Function and chlorine level	m/z	m/z type	m/z formula	Substance
	301.9626	M	$^{13}\text{C}_{12} \text{H}_6 \text{ } ^{35}\text{Cl}_4$	$^{13}\text{C}_{12}$ Cl-4 PCB
	303.9597	M+2	$^{13}\text{C}_{12} \text{H}_6 \text{ } ^{35}\text{Cl}_3 \text{ } ^{37}\text{Cl}$	$^{13}\text{C}_{12}$ Cl-4 PCB
	323.8834	M	$^{12}\text{C}_{12} \text{H}_5 \text{ } ^{35}\text{Cl}_5$	Cl-5 PCB
	325.8804	M+2	$^{12}\text{C}_{12} \text{H}_5 \text{ } ^{35}\text{Cl}_4 \text{ } ^{37}\text{Cl}$	Cl-5 PCB
	327.8775	M+4	$^{12}\text{C}_{12} \text{H}_5 \text{ } ^{35}\text{Cl}_3 \text{ } ^{37}\text{Cl}_2$	Cl-5 PCB
	337.9207	M+2	$^{13}\text{C}_{12} \text{H}_5 \text{ } ^{35}\text{Cl}_4 \text{ } ^{37}\text{Cl}$	$^{13}\text{C}_{12}$ Cl-5 PCB
	339.9178	M+4	$^{13}\text{C}_{12} \text{H}_5 \text{ } ^{35}\text{Cl}_3 \text{ } ^{37}\text{Cl}_2$	$^{13}\text{C}_{12}$ Cl-5 PCB
Fn-4	289.9224	M	$^{12}\text{C}_{12} \text{H}_6 \text{ } ^{35}\text{Cl}_4$	Cl-4 PCB
Cl-4,5,6	291.9194	M+2	$^{12}\text{C}_{12} \text{H}_6 \text{ } ^{35}\text{Cl}_3 \text{ } ^{37}\text{Cl}$	Cl-4 PCB
	293.9165	M+4	$^{12}\text{C}_{12} \text{H}_6 \text{ } ^{35}\text{Cl}_2 \text{ } ^{37}\text{Cl}_2$	Cl-4 PCB
	301.9626	M+2	$^{13}\text{C}_{12} \text{H}_6 \text{ } ^{35}\text{Cl}_3 \text{ } ^{37}\text{Cl}$	$^{13}\text{C}_{12}$ Cl-4 PCB
	303.9597	M+4	$^{13}\text{C}_{12} \text{H}_6 \text{ } ^{35}\text{Cl}_2 \text{ } ^{37}\text{Cl}_2$	$^{13}\text{C}_{12}$ Cl-4 PCB
	323.8834	M	$^{12}\text{C}_{12} \text{H}_5 \text{ } ^{35}\text{Cl}_5$	Cl-5 PCB
	325.8804	M+2	$^{12}\text{C}_{12} \text{H}_5 \text{ } ^{35}\text{Cl}_4 \text{ } ^{37}\text{Cl}$	Cl-5 PCB
	327.8775	M+4	$^{12}\text{C}_{12} \text{H}_5 \text{ } ^{35}\text{Cl}_3 \text{ } ^{37}\text{Cl}_2$	Cl-5 PCB
	330.9792	lock	$\text{C}_7 \text{F}_{15}$	PFK
	337.9207	M+2	$^{13}\text{C}_{12} \text{H}_5 \text{ } ^{35}\text{Cl}_4 \text{ } ^{37}\text{Cl}$	$^{13}\text{C}_{12}$ Cl-5 PCB
	339.9178	M+4	$^{13}\text{C}_{12} \text{H}_5 \text{ } ^{35}\text{Cl}_3 \text{ } ^{37}\text{Cl}_2$	$^{13}\text{C}_{12}$ Cl-5 PCB
	359.8415	M+2	$^{13}\text{C}_{12} \text{H}_4 \text{ } ^{35}\text{Cl}_5 \text{ } ^{37}\text{Cl}$	Cl-6 PCB
	361.8385	M+4	$^{13}\text{C}_{12} \text{H}_4 \text{ } ^{35}\text{Cl}_4 \text{ } ^{37}\text{Cl}_2$	Cl-6 PCB
	363.8356	M+6	$^{13}\text{C}_{12} \text{H}_4 \text{ } ^{35}\text{Cl}_3 \text{ } ^{37}\text{Cl}_2$	Cl-6 PCB
	371.8817	M+2	$^{13}\text{C}_{12} \text{H}_4 \text{ } ^{35}\text{Cl}_5 \text{ } ^{37}\text{Cl}$	$^{13}\text{C}_{12}$ Cl-6 PCB
	373.8788	M+4	$^{13}\text{C}_{12} \text{H}_4 \text{ } ^{35}\text{Cl}_4 \text{ } ^{37}\text{Cl}_2$	$^{13}\text{C}_{12}$ Cl-6 PCB
Fn-5	323.8834	M	$^{12}\text{C}_{12} \text{H}_5 \text{ } ^{35}\text{Cl}_5$	Cl-5 PCB

Function and chlorine level	m/z	m/z type	m/z formula	Substance
Cl-5,6,7	325.8804	M+2	$^{12}\text{C}_{12}\text{H}_5\text{ }^{35}\text{Cl}_4\text{ }^{37}\text{Cl}$	Cl-5 PCB
	327.8775	M+4	$^{12}\text{C}_{12}\text{H}_5\text{ }^{35}\text{Cl}_3\text{ }^{37}\text{Cl}_2$	Cl-5 PCB
	337.9207	M+2	$^{13}\text{C}_{12}\text{H}_5\text{ }^{35}\text{Cl}_4\text{ }^{37}\text{Cl}$	$^{13}\text{C}_{12}$ Cl-5 PCB
	339.9178	M+4	$^{13}\text{C}_{12}\text{H}_5\text{ }^{35}\text{Cl}_3\text{ }^{37}\text{Cl}_2$	$^{13}\text{C}_{12}$ Cl-5 PCB
	354.9792	lock	C_9F_{13}	PFK
	359.8415	M+2	$^{12}\text{C}_{12}\text{H}_4\text{ }^{35}\text{Cl}_5\text{ }^{37}\text{Cl}$	Cl-6 PCB
	361.8385	M+4	$^{12}\text{C}_{12}\text{H}_4\text{ }^{35}\text{Cl}_4\text{ }^{37}\text{Cl}_2$	Cl-6 PCB
	363.8356	M+6	$^{12}\text{C}_{12}\text{H}_4\text{ }^{35}\text{Cl}_3\text{ }^{37}\text{Cl}_3$	Cl-6 PCB
	371.8817	M+2	$^{13}\text{C}_{12}\text{H}_4\text{ }^{35}\text{Cl}_5\text{ }^{37}\text{Cl}$	$^{13}\text{C}_{12}$ Cl-6 PCB
	373.8788	M+4	$^{13}\text{C}_{12}\text{H}_4\text{ }^{35}\text{Cl}_4\text{ }^{37}\text{Cl}_2$	$^{13}\text{C}_{12}$ Cl-6 PCB
	393.8025	M+2	$^{12}\text{C}_{12}\text{H}_3\text{ }^{35}\text{Cl}_6\text{ }^{37}\text{Cl}$	Cl-7 PCB
	395.7995	M+4	$^{12}\text{C}_{12}\text{H}_3\text{ }^{35}\text{Cl}_5\text{ }^{37}\text{Cl}_2$	Cl-7 PCB
	397.7966	M+6	$^{12}\text{C}_{12}\text{H}_3\text{ }^{35}\text{Cl}_4\text{ }^{37}\text{Cl}_3$	Cl-7 PCB
	405.8428	M+2	$^{13}\text{C}_{12}\text{H}_3\text{ }^{35}\text{Cl}_6\text{ }^{37}\text{Cl}$	$^{13}\text{C}_{12}$ Cl-7 PCB
	407.8398	M+4	$^{13}\text{C}_{12}\text{H}_3\text{ }^{35}\text{Cl}_5\text{ }^{37}\text{Cl}_2$	$^{13}\text{C}_{12}$ Cl-7 PCB
	454.9728	QC	$\text{C}_{11}\text{F}_{17}$	PFK
Fn-6	393.8025	M+2	$^{12}\text{C}_{12}\text{H}_3\text{ }^{35}\text{Cl}_6\text{ }^{37}\text{Cl}$	Cl-7 PCB
Cl-7,8,9,10	395.7995	M+4	$^{12}\text{C}_{12}\text{H}_3\text{ }^{35}\text{Cl}_5\text{ }^{37}\text{Cl}_2$	Cl-7 PCB
	397.7966	M+6	$^{12}\text{C}_{12}\text{H}_3\text{ }^{35}\text{Cl}_4\text{ }^{37}\text{Cl}_3$	Cl-7 PCB
	405.8428	M+2	$^{13}\text{C}_{12}\text{H}_3\text{ }^{35}\text{Cl}_6\text{ }^{37}\text{Cl}$	$^{13}\text{C}_{12}$ Cl-7 PCB
	407.8398	M+4	$^{13}\text{C}_{12}\text{H}_3\text{ }^{35}\text{Cl}_5\text{ }^{37}\text{Cl}_2$	$^{13}\text{C}_{12}$ Cl-7 PCB
	427.7635	M+2	$^{12}\text{C}_{12}\text{H}_2\text{ }^{35}\text{Cl}_7\text{ }^{37}\text{Cl}$	Cl-8 PCB
	429.7606	M+4	$^{12}\text{C}_{12}\text{H}_2\text{ }^{35}\text{Cl}_6\text{ }^{37}\text{Cl}_2$	Cl-8 PCB
	431.7576	M+6	$^{12}\text{C}_{12}\text{H}_2\text{ }^{35}\text{Cl}_5\text{ }^{37}\text{Cl}_3$	Cl-8 PCB

Function and chlorine level	m/z	m/z type	m/z formula	Substance
	439.8038	M+2	$^{13}\text{C}_{12} \text{H}_2 \text{}^{35}\text{Cl}_7 \text{}^{37}\text{Cl}$	$^{13}\text{C}_{12}$ CI-8 PCB
	441.8008	M+4	$^{13}\text{C}_{12} \text{H}_2 \text{}^{35}\text{Cl}_6 \text{}^{37}\text{Cl}_2$	$^{13}\text{C}_{12}$ CI-8 PCB
	442.9728	QC	$\text{C}_{10} \text{F}_{13}$	PFK
	454.9728	lock	$\text{C}_{11} \text{F}_{13}$	PFK
	461.7246	M+2	$^{12}\text{C}_{12} \text{H}_1 \text{}^{35}\text{Cl}_8 \text{}^{37}\text{Cl}$	CI-9 PCB
	463.7216	M+4	$^{12}\text{C}_{12} \text{H}_1 \text{}^{35}\text{Cl}_7 \text{}^{37}\text{Cl}_2$	CI-9 PCB
	465.7187	M+6	$^{12}\text{C}_{12} \text{H}_1 \text{}^{35}\text{Cl}_6 \text{}^{37}\text{Cl}_3$	CI-9 PCB
	473.7648	M+2	$^{13}\text{C}_{12} \text{H}_1 \text{}^{35}\text{Cl}_8 \text{}^{37}\text{Cl}$	$^{13}\text{C}_{12}$ CI-9 PCB
	475.7619	M+4	$^{13}\text{C}_{12} \text{H}_1 \text{}^{35}\text{Cl}_7 \text{}^{37}\text{Cl}_2$	$^{13}\text{C}_{12}$ CI-9 PCB
	495.6856	M+2	$^{13}\text{C}_{12} \text{H}_4 \text{}^{35}\text{Cl}_9 \text{}^{37}\text{Cl}$	CI-10 PCB
	497.6826	M+4	$^{12}\text{C}_{12} \text{}^{35}\text{Cl}_8 \text{}^{37}\text{Cl}_2$	CI-10 PCB
	499.6797	M+6	$^{12}\text{C}_{12} \text{}^{35}\text{Cl}_7 \text{}^{37}\text{Cl}_3$	CI-10 PCB
	507.7258	M+2	$^{13}\text{C}_{12} \text{H}_4 \text{}^{35}\text{Cl}_9 \text{}^{37}\text{Cl}$	$^{13}\text{C}_{12}$ CI-10 PCB
	509.7229	M+4	$^{13}\text{C}_{12} \text{H}_4 \text{}^{35}\text{Cl}_8 \text{}^{37}\text{Cl}_2$	$^{13}\text{C}_{12}$ CI-10 PCB
	511.7199	M+6	$^{13}\text{C}_{12} \text{H}_4 \text{}^{35}\text{Cl}_8 \text{}^{37}\text{Cl}_4$	$^{13}\text{C}_{12}$ CI-10 PCB

1. Isotopic masses used for accurate mass calculation

^1H	1.0078
^{12}C	12.0000
^{13}C	13.0034
^{35}Cl	34.9689
^{37}Cl	36.9659
^{19}F	18.9984

Table 8. Theoretical ion abundance ratios and QC limits

Chlorine atoms	m/z's forming ratio	Theoretical ratio	Lower QC limit	Upper QC limit
1	m/m+2	3.13	2.66	3.60
2	m/(m+2)	1.56	1.33	1.79
3	m/(m+2)	1.04	0.88	1.20
4	m/(m+2)	0.77	0.65	0.89
5	(m+2)/(m+4)	1.55	1.32	1.78
6	(m+2)/(m+4)	1.24	1.05	1.43
7	(m+2)/(m+4)	1.05	0.89	1.21
8	(m+2)/(m+4)	0.89	0.76	1.02
9	(m+2)/(m+4)	0.77	0.65	0.89
10	(m+2)/(m+4)	0.69	0.59	0.79

Table 9. Suggested Sample Quantities to be Extracted for Various Matrices¹

Sample matrix ²	Example	Percent solids	Phase	Quantity extracted
Single-phase				
Aqueous	Drinking water	<1	— ³	1000 mL
	Groundwater			
	Treated wastewater			
Solid	Dry soil	>20	Solid	10 g
	Compost			
	Ash			
Organic	Waste solvent	<1	Organic	10 g
	Waste oil			
	Organic polymer			
Tissue	Fish	—	Organic	10 g
	Human adipose			
Multi-phase				
Liquid/Solid				
Aqueous/Solid	Wet soil	1-30	Solid	10 g
	Untreated effluent			
	Digested municipal sludge			
	Filter cake			
	Paper pulp			
Organic/solid	Industrial sludge	1-100	Both	10 g
	Oily waste			
Liquid/Liquid				
Aqueous/organic	In-process effluent	<1	Organic	10 g
	Untreated effluent			
	Drum waste			
Aqueous/organic/solid	Untreated effluent	>1	Organic & solid	10 g
	Drum waste			

1. The quantity of sample to be extracted is adjusted to provide 10 g of solids (dry weight). One liter of aqueous samples containing one percent solids will contain 10 grams of solids. For aqueous samples containing greater than one percent solids, a lesser volume is used so that 10 grams of solids (dry weight) will be extracted.
2. The sample matrix may be amorphous for some samples. In general, when the CBs are in contact with a multi-phase system in which one of the phases is water, they will be preferentially dispersed in or adsorbed on the alternate phase because of their low solubility in water.
3. Aqueous samples are filtered after spiking with the labeled compounds. The filtrate and the materials trapped on the filter are extracted separately, and the extracts are combined for cleanup and analysis.

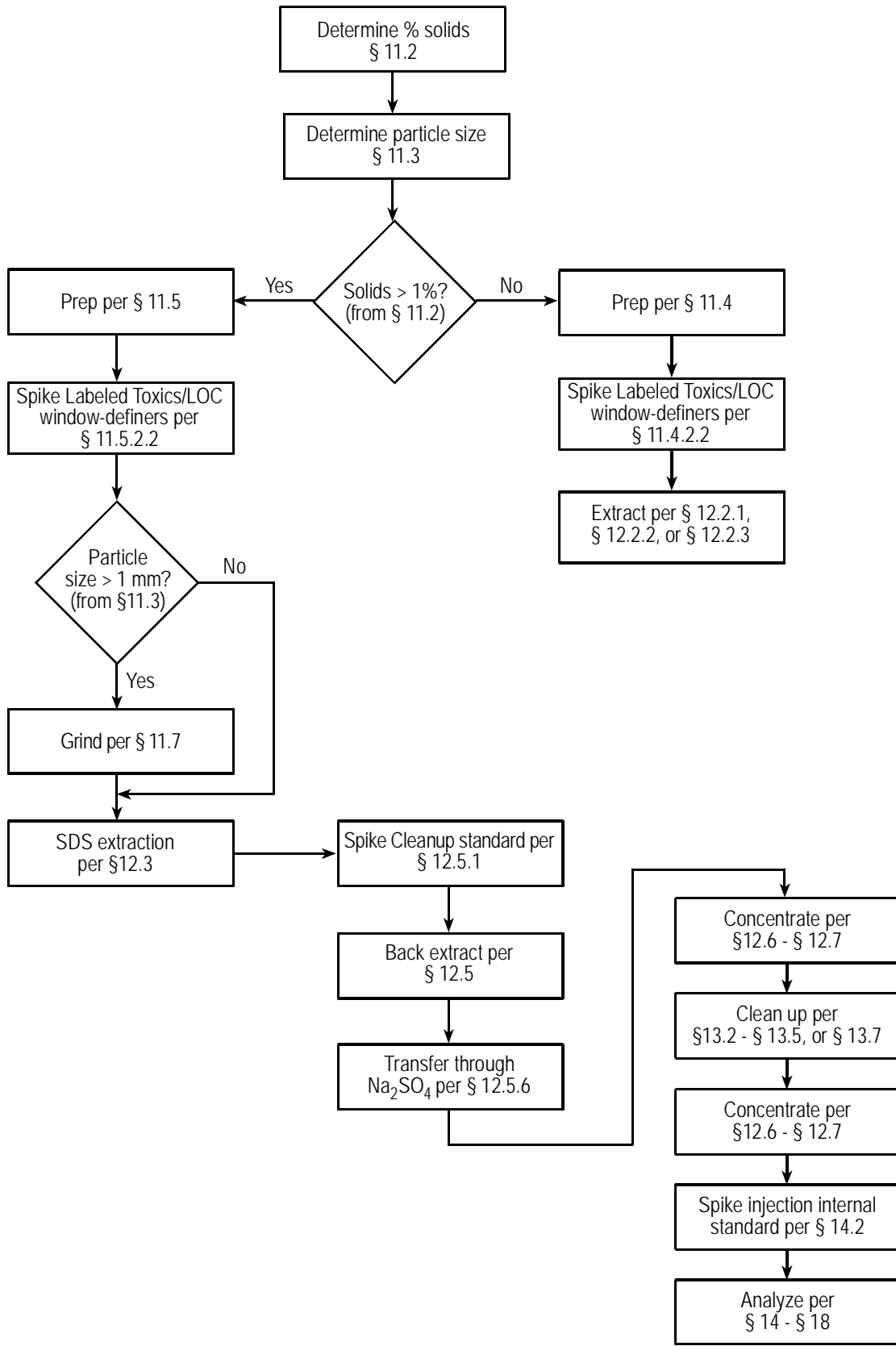

SCC-99-020

Figure 1 Flow Chart for Analysis of Aqueous and Solid Samples

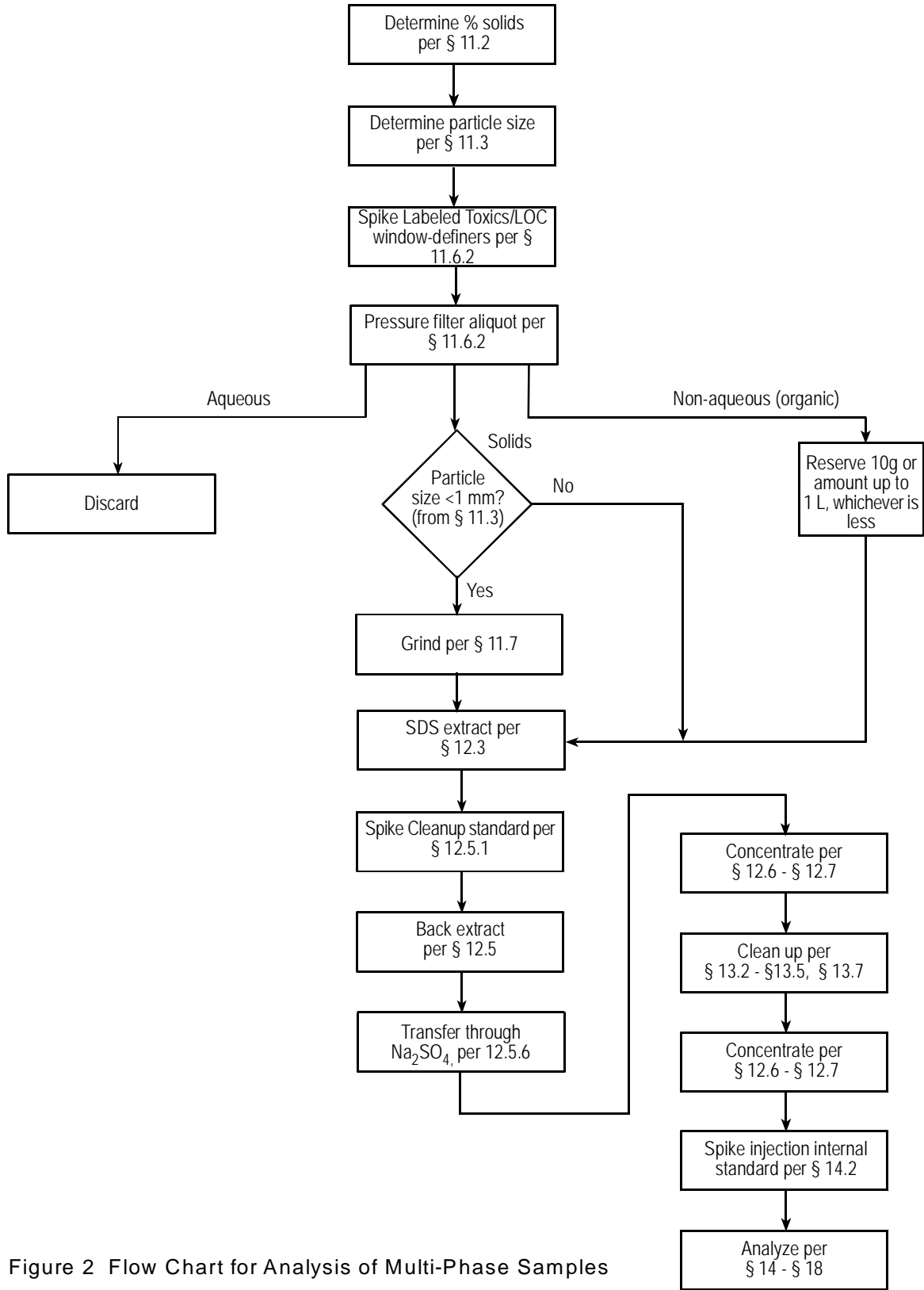

Figure 2 Flow Chart for Analysis of Multi-Phase Samples

SCC-99-018

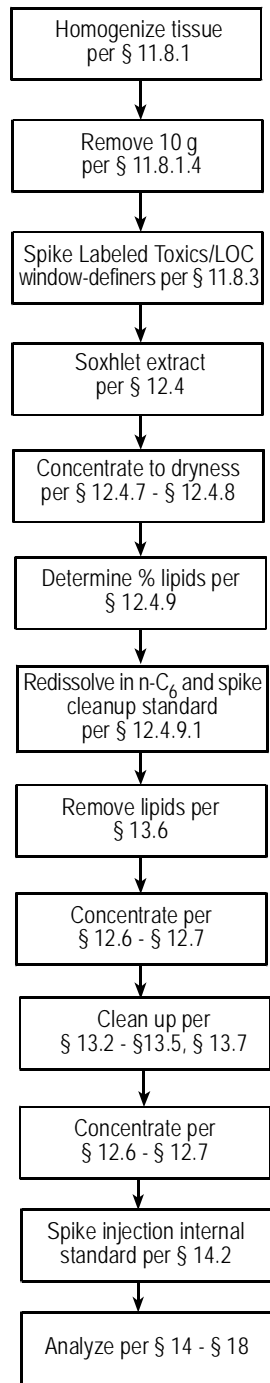

Figure 3 Flow Chart for Analysis of Tissue Samples

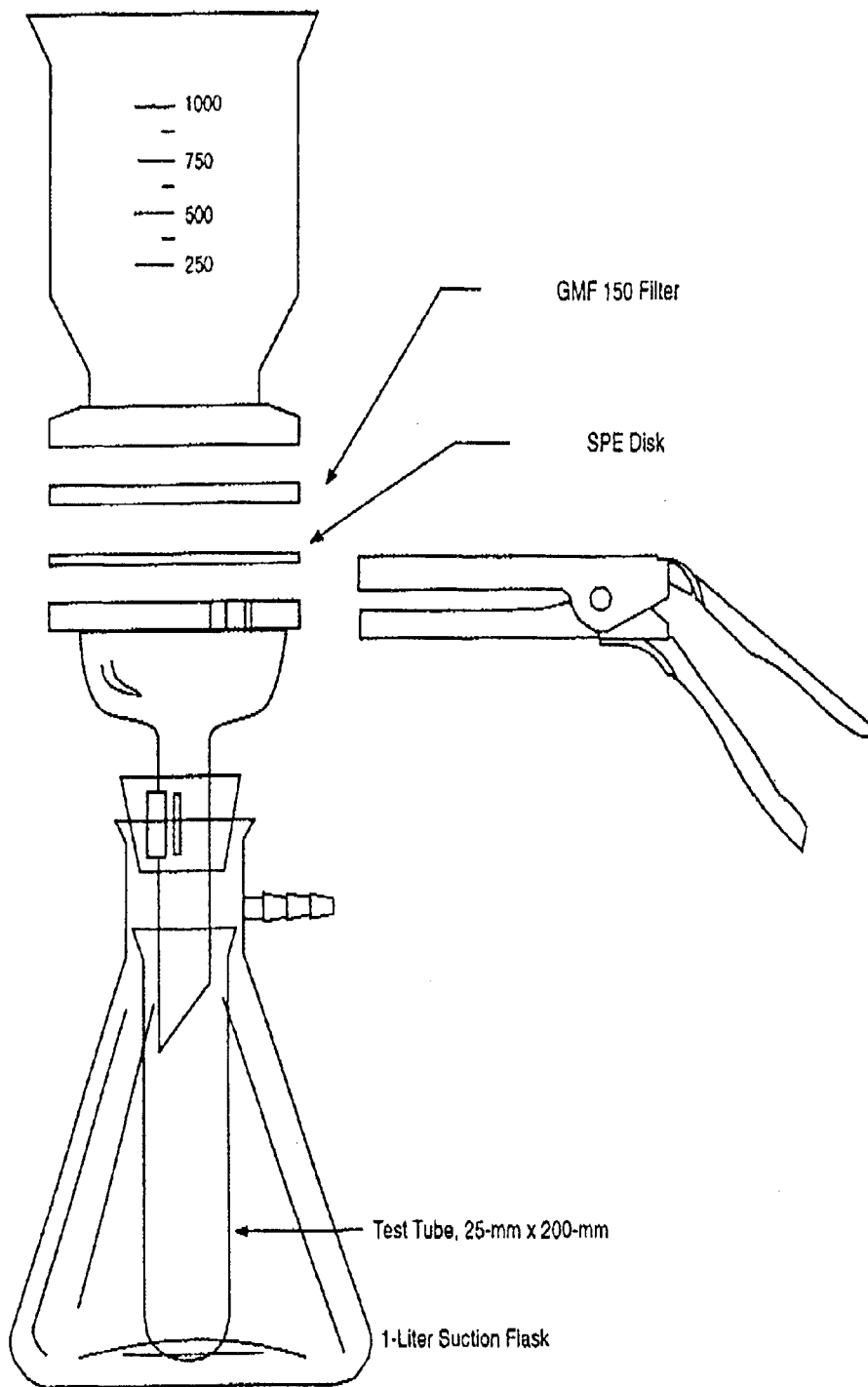
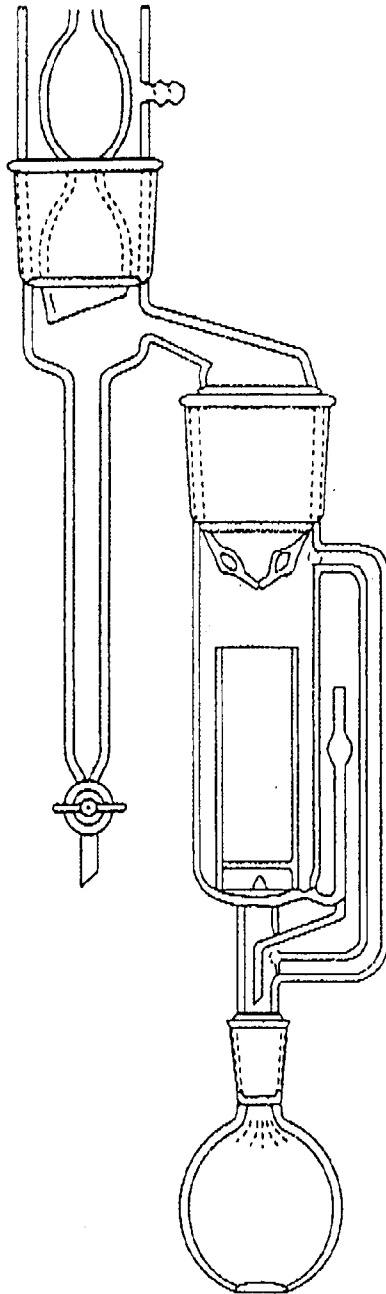

Figure 4 Solid-phase Extraction Apparatus



62-027-02

Figure 5 Soxhlet/Dean-Stark Extractor

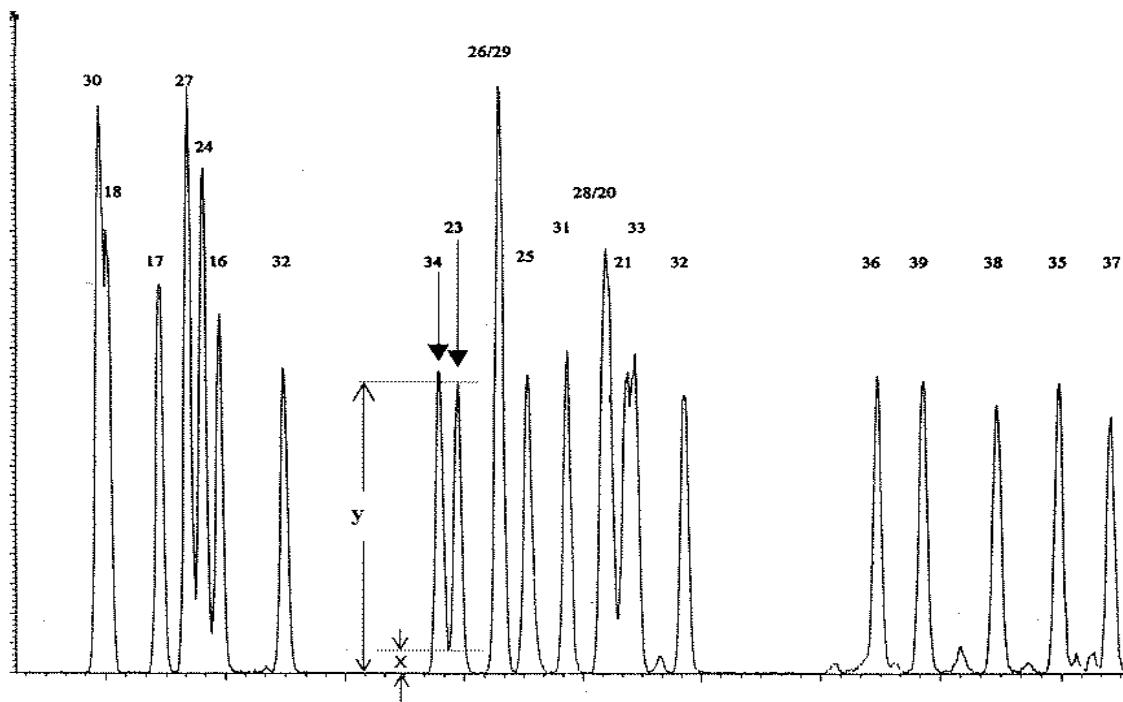

Figure 6 Octyl column resolution test #1: Separation of Cl-3 congeners 34 and 23 with valley <40% (i.e. $100x/y < 40\%$)

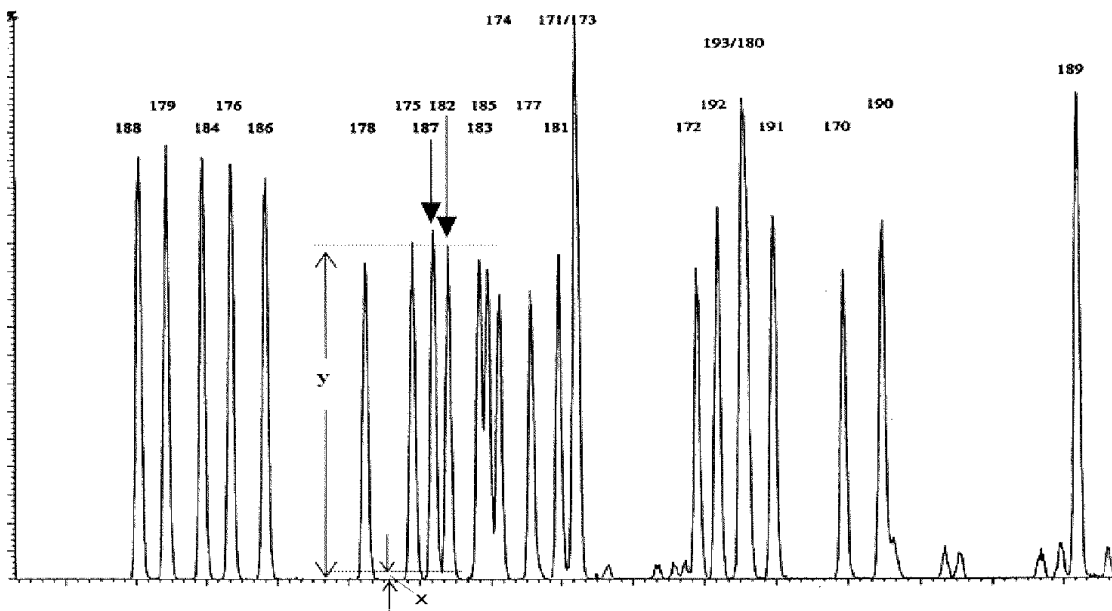

Figure 7 Octyl column resolution test #2: Separation of Cl-7 congeners 187 and 182 with valley <40% (i.e. $100 x/y < 40\%$)

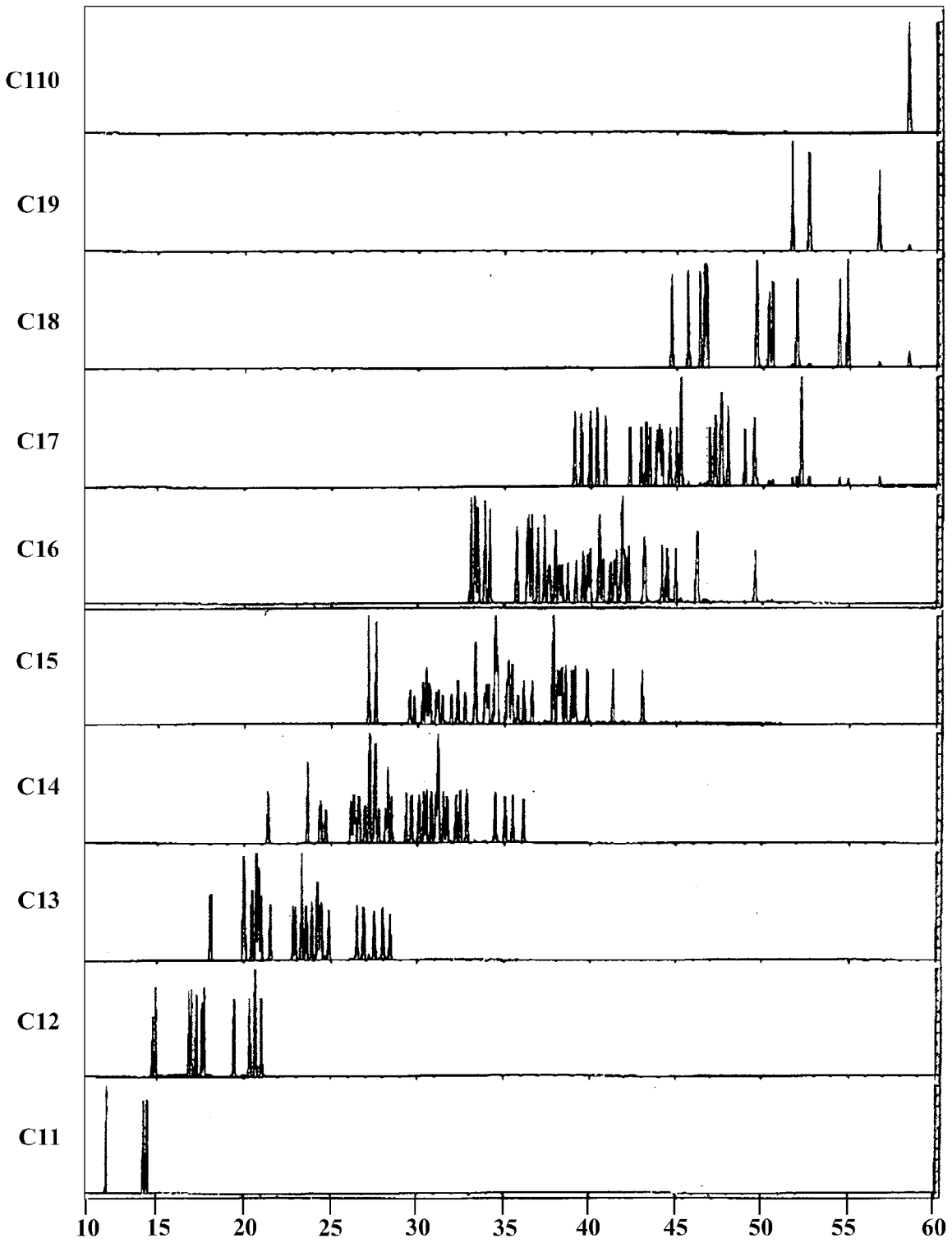

Figure 8 CB congeners at each level of chlorination on the SPB-octyl column

24.0 Glossary

These definitions and purposes are specific to this Method but have been conformed to common usage to the extent possible.

24.1 Units of weight and measure and their abbreviations

24.1.1 Symbols

°C	degrees Celsius
μL	microliter
μm	micrometer
<	less than
>	greater than
%	percent

24.1.2 Alphabetical abbreviations

cm	centimeter
g	gram
h	hour
ID	inside diameter
in.	inch
L	liter
M	Molecular ion
m	meter
mg	milligram
min	minute
mL	milliliter
mm	millimeter
m/z	mass-to-charge ratio
N	normal; gram molecular weight of solute divided by hydrogen equivalent of solute, per liter of solution
OD	outside diameter
pg	picogram
ppb	part-per-billion
ppm	part-per-million
ppq	part-per-quadrillion
ppt	part-per-trillion
psig	pounds-per-square inch gauge
v/v	volume per unit volume
w/v	weight per unit volume

24.2 Definitions and acronyms (in alphabetical order).

Analyte—A CB tested for by this Method. The analytes are listed in Table 1.

Calibration standard (CAL)—A solution prepared from a secondary standard and/or stock solutions and used to calibrate the response of the HRGC/HRMS instrument.

Calibration verification standard (VER)—The mid-point calibration standard (CS-3) that is used to verify calibration. See Table 5.

CB—chlorinated biphenyl congener. One of the 209 individual chlorinated biphenyl congeners determined using this Method. The 209 CBs are listed in Table 1.

CS-0.2, CS-1, CS-2, CS-3, CS-4, CS-5—See Calibration standards and Table 5.

DeCB—decachlorobiphenyl (PCB 209)

DiCB—dichlorobiphenyl

Estimated method detection limit (EMDL)—The lowest concentration at which a CB can be detected with common laboratory interferences present. EMDLs are listed in Table 2.

Estimated minimum level (EML)—The lowest concentration at which a CB can be measured reliably with common laboratory interferences present. EMLs are listed in Table 2.

Field blank—An aliquot of reagent water or other reference matrix that is placed in a sample container in the laboratory or the field, and treated as a sample in all respects, including exposure to sampling site conditions, storage, preservation, and all analytical procedures. The purpose of the field blank is to determine if the field or sample transporting procedures and environments have contaminated the sample.

GC—Gas chromatograph or gas chromatography

GPC—Gel permeation chromatograph or gel permeation chromatography

HpCB—heptachlorobiphenyl

HPLC—High performance liquid chromatograph or high performance liquid chromatography

HRGC—High resolution GC

HRMS—High resolution MS

HxCB—hexachlorobiphenyl

Labeled injection internal standard—All five, or any one of the five, $^{13}\text{C}_{12}$ -labeled CB congeners spiked into the concentrated extract immediately prior to injection of an aliquot of the extract into the HRGC/HRMS. The five Labeled injection internal standards in this Method are CBs with IUPAC numbers 9, 52, 101, 138, and 194.

Internal standard—a labeled compound used as a reference for quantitation of other labeled compounds and for quantitation of native CB congeners other than the congener of which it is a labeled analog. See Internal standard quantitation.

Internal standard quantitation—A means of determining the concentration of (1) a naturally occurring (native) compound by reference to a compound other than its labeled analog and (2) a labeled compound by reference to another labeled compound.

IPR—Initial precision and recovery; four aliquots of a reference matrix spiked with the analytes of interest and labeled compounds and analyzed to establish the ability of the laboratory to generate acceptable precision and recovery. An IPR is performed prior to the first time this Method is used and any time the Method or instrumentation is modified.

Isotope dilution quantitation—A means of determining a naturally occurring (native) compound by reference to the same compound in which one or more atoms has been isotopically enriched. In this Method, all 12 carbon atoms in the biphenyl molecule are enriched with carbon-13 to produce $^{13}\text{C}_{12}$ -labeled analogs of the chlorinated biphenyls. The $^{13}\text{C}_{12}$ -labeled CBs are spiked into each sample and allow identification and correction of the concentration of the native compounds in the analytical process.

K-D—Kuderna-Danish concentrator; a device used to concentrate the analytes in a solvent

Laboratory blank—See Method blank

Laboratory control sample (LCS)—See Ongoing precision and recovery standard (OPR)

Laboratory reagent blank—See Method blank

May—This action, activity, or procedural step is neither required nor prohibited.

May not—This action, activity, or procedural step is prohibited.

Method blank—An aliquot of reagent water that is treated exactly as a sample including exposure to all glassware, equipment, solvents, reagents, internal standards, and surrogates that are used with samples. The Method blank is used to determine if analytes or interferences are present in the laboratory environment, the reagents, or the apparatus.

Minimum level of quantitation (ML)—The level at which the entire analytical system must give a recognizable signal and acceptable calibration point for the analyte. It is equivalent to the concentration of the lowest calibration standard, assuming that all Method-specified sample weights, volumes, and cleanup procedures have been employed.

MoCB—monochlorobiphenyl

MS—Mass spectrometer or mass spectrometry

Must—This action, activity, or procedural step is required.

NoCB—nonachlorobiphenyl

OcCB—octachlorobiphenyl

OPR—Ongoing precision and recovery standard (OPR); a method blank spiked with known quantities of analytes. The OPR is analyzed exactly like a sample. Its purpose is to assure that the results produced by the laboratory remain within the limits specified in this Method for precision and recovery.

Perfluorokerosene (PFK)—A mixture of compounds used to calibrate the exact m/z scale in the HRMS.

Preparation blank—See Method blank

Quality control check sample (QCS)—A sample containing all or a subset of the analytes at known concentrations. The QCS is obtained from a source external to the laboratory or is prepared from a source of standards different from the source of calibration standards. It is used to check laboratory performance with test materials prepared external to the normal preparation process.

PeCB—pentachlorobiphenyl

PCB—polychlorinated biphenyl

Reagent water—water demonstrated to be free from the analytes of interest and potentially interfering substances at the method detection limit for the analyte.

Relative standard deviation (RSD)—The standard deviation times 100 divided by the mean. Also termed "coefficient of variation."

RF—Response factor. See Section 10.5

RR—Relative response. See Section 10.4

RSD—See Relative standard deviation

SDS—Soxhlet/Dean-Stark extractor; an extraction device applied to the extraction of solid and semi-solid materials (Reference 11 and Figure 5).

Signal-to-noise ratio (S/N)—The height of the signal as measured from the mean (average) of the noise to the peak maximum divided by the width of the noise.

Should—This action, activity, or procedural step is suggested but not required.

SICP—Selected ion current profile; the line described by the signal at an exact m/z.

SPE—Solid-phase extraction; an extraction technique in which an analyte is extracted from an aqueous sample by passage over or through a material capable of reversibly adsorbing the analyte. Also termed liquid-solid extraction.

Stock solution—A solution containing an analyte that is prepared using a reference material traceable to EPA, the National Institute of Science and Technology (NIST), or a source that will attest to the purity and authenticity of the reference material.

TeCB—tetrachlorobiphenyl

TEF—Toxicity equivalency factor; an estimate of the toxicity of a specific congener relative to 2,3,7,8-tetrachlorodibenzo-*p*-dioxin.

TEQ—the toxicity equivalent concentration in an environmental sample. It is the sum of the concentrations of each individual toxic PCB and each individual 2,3,7,8-substituted, tetra-through octachlorinated, dibenzo-*p*-dioxin and dibenzofuran multiplied by their respective TEFs (Reference 1).

TEQ_{PCB}—the portion of the TEQ attributable to the toxic PCBs.

TrCB—trichlorobiphenyl

Unique GC resolution or uniquely resolved—Two adjacent chromatographic peaks in which the height of the valley is less than 40 percent of the height of the shorter peak (See section 6.9.1.1.2 and Figures 6 and 7 for unique resolution specific to the SPB-octyl column).

VER—See Calibration verification.

Annex A - Preliminary information for determination of 209 CBs on the DB-1 column

1 Column and Conditions

- 1.1** Column—30±5-m long x 0.25±0.02-mm ID; 0.25-μm film DB-1 (J&W, or equivalent).
- 1.2** Suggested GC operating conditions:
- | | |
|------------------------|--|
| Injector temperature: | 270 °C |
| Interface temperature: | 290 °C |
| Initial temperature: | 75 °C |
| Initial time: | 2 minutes |
| Temperature program: | 75-150 °C @ 15 °C/minute
150-270 °C @ 2.5 °C/minute |
| Final time: | 7 minutes |
| Carrier gas velocity: | 40 cm/sec @ 200 °C |

Note: *The GC conditions may be optimized for compound separation and sensitivity. Once optimized, the same GC conditions must be used for the analysis of all standards, blanks, IPR and OPR aliquots, and samples.*

2 Operating information

- 2.1** Congener solutions—Mixes of individual congeners that will allow separation of all 209 congeners on the DB-1 column had not been developed at the date of writing of Revision A to Method 1668.
- 2.2** Elution order data—The congener mixes developed for the SPB-octyl column (Table 4 of Method 1668) were run on the DB-1 column. Although some congeners in these mixes co-elute on the DB-1 column, the mixes allow determination of retention times the DB-1 column. These retention times are shown in Annex Table A-1
- 2.2** Window-defining congeners—The beginning and ending congeners at each level of chlorination are the same as those for the SPB-octyl column. See Table 2 in Method 1668.
- 2.3** Scan descriptors—The 6-function scan descriptors are shown in Annex Table A-2

Table A-1. Retention time (RT) references, quantitation references, relative retention times (RRTs), estimated detection limits (EMDLs), and estimated minimum levels (EMLs) for CB congeners using a DB-1 column.

Labeled or native CB ¹	IUPAC number ²	Retention time and quantitation references	IUPAC number	RT	RRT	RRT QC limits ³
¹³ C ₁₂ -2-MoCB ⁴	1L	¹³ C ₁₂ -4-MoCB ^{4,5}	3L	09:17	0.8855	0.8776-0.8935
2-MoCB	1	¹³ C ₁₂ -2-MoCB ⁴	1L	09:17	1.0000	0.9964-1.0072
3-MoCB	2	¹³ C ₁₂ -4-MoCB ^{4,5}	3L	10:22	0.9889	0.9809-0.9968
¹³ C ₁₂ -4-MoCB ^{4,5}	3L	¹³ C ₁₂ -2,2',5,5'-TeCB ⁷	52L	10:29	0.5561	0.5473-0.5650
4-MoCB	3	¹³ C ₁₂ -4-MoCB ^{4,5}	3L	10:29	1.0000	0.9968-1.0064
¹³ C ₁₂ -2,2'-DiCB ⁴	4L	¹³ C ₁₂ -4,4'-DiCB ^{4,5}	15L	11:08	0.7591	0.7477-0.7705
2,2'-DiCB	4	¹³ C ₁₂ -2,2'-DiCB ⁴	4L	11:08	1.0000	0.9925-1.0075
2,6-DiCB	10	¹³ C ₁₂ -4,4'-DiCB ^{4,5}	15L	11:10	0.7614	0.7500-0.7727
2,5-DiCB	9	¹³ C ₁₂ -4,4'-DiCB ^{4,5}	15L	12:08	0.8273	0.8216-0.8330
2,4-DiCB	7	¹³ C ₁₂ -4,4'-DiCB ^{4,5}	15L	12:09	0.8284	0.8227-0.8341
2,3'-DiCB	6	¹³ C ₁₂ -4,4'-DiCB ^{4,5}	15L	12:31	0.8534	0.8477-0.8591
2,4'-DiCB ⁶	8	¹³ C ₁₂ -4,4'-DiCB ^{4,5}	15L	12:43	0.8670	0.8614-0.8727
2,3-DiCB	5	¹³ C ₁₂ -4,4'-DiCB ^{4,5}	15L	12:46	0.8705	0.8648-0.8761
¹³ C ₁₂ -2,2',6-TrCB ⁴	19L	¹³ C ₁₂ -2,4,4'-TrCB ⁵	28L	13:31	0.7990	0.7892-0.8089
2,2',6-TrCB	19	¹³ C ₁₂ -2,2',6-TrCB ⁴	19L	13:31	1.0000	0.9975-1.0049
3,5-DiCB	14	¹³ C ₁₂ -4,4'-DiCB ^{4,5}	15L	13:36	0.9273	0.9216-0.9330
2,4,6-TrCB	30	¹³ C ₁₂ -2,4,4'-TrCB ⁵	28L	14:06	0.8335	0.8286-0.8384
3,3'-DiCB	11	¹³ C ₁₂ -4,4'-DiCB ^{4,5}	15L	14:11	0.9670	0.9614-0.9727
3,4'-DiCB	13	¹³ C ₁₂ -4,4'-DiCB ^{4,5}	15L	14:26	0.9841	0.9784-0.9898
3,4-DiCB	12	¹³ C ₁₂ -4,4'-DiCB ^{4,5}	15L	14:27	0.9852	0.9795-0.9909
2,2',5-TrCB ⁶	18	¹³ C ₁₂ -2,4,4'-TrCB ⁵	28L	14:36	0.8631	0.8581-0.8680
¹³ C ₁₂ -4,4'-DiCB ^{4,5}	15L	¹³ C ₁₂ -2,2',5,5'-TeCB ⁷	52L	14:40	0.7781	0.7692-0.7869
4,4'-DiCB	15	¹³ C ₁₂ -4,4'-DiCB ^{4,5}	15L	14:40	1.0000	0.9977-1.0043
2,2',4-TrCB	17	¹³ C ₁₂ -2,4,4'-TrCB ⁵	28L	14:43	0.8700	0.8650-0.8749
2,3',6-TrCB	27	¹³ C ₁₂ -2,4,4'-TrCB ⁵	28L	15:06	0.8926	0.8877-0.8975

Labeled or native CB ¹	IUPAC number ²	Retention time and quantitation references	IUPAC number	RT	RRT	RRT QC limits ³
2,3,6-TrCB	24	¹³ C ₁₂ -2,4,4'-TrCB ⁵	28L	15:06	0.8926	0.8877-0.8975
2,2',3-TrCB	16	¹³ C ₁₂ -2,4,4'-TrCB ⁵	28L	15:26	0.9123	0.9074-0.9172
2,4',6-TrCB	32	¹³ C ₁₂ -2,4,4'-TrCB ⁵	28L	15:29	0.9153	0.9103-0.9202
¹³ C ₁₂ -2,2',6,6'-TeCB ⁴	54L	¹³ C ₁₂ -3,3',4,4'-TeCB ^{4,5,9}	77L	16:02	0.6139	0.6075-0.6203
2,2',6,6'-TeCB	54	¹³ C ₁₂ -2,2',6,6'-TeCB ⁴	54L	16:02	1.0000	0.9979-1.0042
2',3,5-TrCB	34	¹³ C ₁₂ -2,4,4'-TrCB ⁵	28L	16:03	0.9488	0.9438-0.9537
2,3,5-TrCB	23	¹³ C ₁₂ -2,4,4'-TrCB ⁵	28L	16:07	0.9527	0.9478-0.9576
2,4,5-TrCB	29	¹³ C ₁₂ -2,4,4'-TrCB ⁵	28L	16:18	0.9635	0.9586-0.9685
2,3',5-TrCB	26	¹³ C ₁₂ -2,4,4'-TrCB ⁵	28L	16:29	0.9744	0.9695-0.9793
2,3',4-TrCB	25	¹³ C ₁₂ -2,4,4'-TrCB ⁵	28L	16:36	0.9813	0.9764-0.9862
2,4',5-TrCB	31	¹³ C ₁₂ -2,4,4'-TrCB ⁵	28L	16:52	0.9970	0.9921-1.0020
¹³ C ₁₂ -2,4,4'-TrCB ⁵	28L	¹³ C ₁₂ -2,2',5,5'-TeCB ⁷	52L	16:55	0.8974	0.8930-0.9019
2,4,4'-TrCB ⁶	28	¹³ C ₁₂ -2,4,4'-TrCB ⁵	28L	16:55	1.0000	0.9980-1.0039
2,2',4,6-TeCB	50	¹³ C ₁₂ -3,3',4,4'-TeCB ^{4,5,9}	77L	16:55	0.6477	0.6414-0.6541
2,3,4-TrCB	21	¹³ C ₁₂ -2,4,4'-TrCB ⁵	28L	17:21	1.0256	1.0207-1.0305
2,2',5,6'-TeCB	53	¹³ C ₁₂ -3,3',4,4'-TeCB ^{4,5,9}	77L	17:26	0.6675	0.6611-0.6739
2,3,3'-TrCB	20	¹³ C ₁₂ -2,4,4'-TrCB ⁵	28L	17:22	1.0266	1.0217-1.0315
2',3,4-TrCB	33	¹³ C ₁₂ -2,4,4'-TrCB ⁵	28L	17:24	1.0286	1.0236-1.0335
2,2',4,6'-TeCB	51	¹³ C ₁₂ -3,3',4,4'-TeCB ^{4,5,9}	77L	17:42	0.6777	0.6713-0.6841
2,3,4'-TrCB	22	¹³ C ₁₂ -2,4,4'-TrCB ⁵	28L	17:43	1.0473	1.0424-1.0522
2,2',3,6-TeCB	45	¹³ C ₁₂ -3,3',4,4'-TeCB ^{4,5,9}	77L	18:00	0.6892	0.6828-0.6956
3,3',5-TrCB	36	¹³ C ₁₂ -2,4,4'-TrCB ⁵	28L	18:16	1.0798	1.0749-1.0847
2,2',3,6'-TeCB	46	¹³ C ₁₂ -3,3',4,4'-TeCB ^{4,5,9}	77L	18:24	0.7045	0.6981-0.7109
3,4',5-TrCB	39	¹³ C ₁₂ -2,4,4'-TrCB ⁵	28L	18:37	1.1005	1.0956-1.1054
¹³ C ₁₂ -2,2',5,5'-TeCB ⁷	52L	¹³ C ₁₂ -2,2',5,5'-TeCB ⁷	52L	18:51	1.0000	0.9956-1.0044
2,2',5,5'-TeCB ⁶	52	¹³ C ₁₂ -3,3',4,4'-TeCB ^{4,5,9}	77L	18:51	0.7218	0.7154-0.7281
2,3',4,6-TeCB	69	¹³ C ₁₂ -3,3',4,4'-TeCB ^{4,5,9}	77L	18:52	0.7224	0.7160-0.7288
2,3',5',6-TeCB	73	¹³ C ₁₂ -3,3',4,4'-TeCB ^{4,5,9}	77L	18:57	0.7256	0.7192-0.7320

Method 1668, Revision A

Labeled or native CB ¹	IUPAC number ²	Retention time and quantitation references	IUPAC number	RT	RRT	RRT QC limits ³
2,2',4,5'-TeCB	49	¹³ C ₁₂ -3,3',4,4'-TeCB ^{4,5,9}	77L	19:00	0.7275	0.7211-0.7339
2,2',3,5'-TeCB	43	¹³ C ₁₂ -3,3',4,4'-TeCB ^{4,5,9}	77L	19:04	0.7301	0.7237-0.7364
3,4,5-TrCB	38	¹³ C ₁₂ -2,4,4'-TrCB ⁵	28L	19:12	1.1350	1.1300-1.1399
2,2',4,4'-TeCB	47	¹³ C ₁₂ -3,3',4,4'-TeCB ^{4,5,9}	77L	19:15	0.7371	0.7307-0.7435
2,4,4',6'-TeCB	75	¹³ C ₁₂ -3,3',4,4'-TeCB ^{4,5,9}	77L	19:20	0.7403	0.7339-0.7466
2,2',4,5'-TeCB	48	¹³ C ₁₂ -3,3',4,4'-TeCB ^{4,5,9}	77L	19:20	0.7403	0.7339-0.7466
2,3,5,6'-TeCB	65	¹³ C ₁₂ -3,3',4,4'-TeCB ^{4,5,9}	77L	19:31	0.7473	0.7409-0.7537
2,3,4,6'-TeCB	62	¹³ C ₁₂ -3,3',4,4'-TeCB ^{4,5,9}	77L	19:36	0.7505	0.7441-0.7569
3,3',4-TrCB	35	¹³ C ₁₂ -2,4,4'-TrCB ⁵	28L	19:41	1.1635	1.1586-1.1685
¹³ C ₁₂ -2,2',4,6,6'-PeCB ⁴	104L	¹³ C ₁₂ -2,3',4,4',5-PeCB ^{5,9}	118L	19:45	0.7037	0.6977-0.7096
2,2',4,6,6'-PeCB	104	¹³ C ₁₂ -2,2',4,6,6'-PeCB ⁴	104L	19:45	1.0000	0.9983-1.0034
2,2',3,5'-TeCB ⁶	44	¹³ C ₁₂ -3,3',4,4'-TeCB ^{4,5,9}	77L	19:55	0.7626	0.7562-0.7690
¹³ C ₁₂ -3,4,4'-TrCB ⁴	37L	¹³ C ₁₂ -2,4,4'-TrCB ⁵	28L	20:03	1.1852	1.1803-1.1901
3,4,4'-TrCB	37	¹³ C ₁₂ -3,4,4'-TrCB ⁴	37L	20:03	1.0000	0.9983-1.0033
2,3,3',6'-TeCB	59	¹³ C ₁₂ -3,3',4,4'-TeCB ^{4,5,9}	77L	20:05	0.7690	0.7626-0.7754
2,2',3,4'-TeCB	42	¹³ C ₁₂ -3,3',4,4'-TeCB ^{4,5,9}	77L	20:07	0.7703	0.7639-0.7766
2,3',5,5'-TeCB	72	¹³ C ₁₂ -3,3',4,4'-TeCB ^{4,5,9}	77L	20:36	0.7888	0.7824-0.7951
2,3',4',6'-TeCB	71	¹³ C ₁₂ -3,3',4,4'-TeCB ^{4,5,9}	77L	20:36	0.7888	0.7824-0.7951
2,3,4',6'-TeCB	64	¹³ C ₁₂ -3,3',4,4'-TeCB ^{4,5,9}	77L	20:37	0.7894	0.7830-0.7958
2,2',3,4'-TeCB	41	¹³ C ₁₂ -3,3',4,4'-TeCB ^{4,5,9}	77L	20:39	0.7907	0.7843-0.7971
2,2',3,6,6'-PeCB	96	¹³ C ₁₂ -2,3',4,4',5-PeCB ^{5,9}	118L	20:48	0.7411	0.7352-0.7470
2,3',4,5'-TeCB	68	¹³ C ₁₂ -3,3',4,4'-TeCB ^{4,5,9}	77L	20:52	0.7990	0.7926-0.8054
2,2',3,3'-TeCB	40	¹³ C ₁₂ -3,3',4,4'-TeCB ^{4,5,9}	77L	20:58	0.8028	0.7996-0.8060
2,3,3',5'-TeCB	57	¹³ C ₁₂ -3,3',4,4'-TeCB ^{4,5,9}	77L	21:21	0.8175	0.8143-0.8207
2,2',4,5',6'-PeCB	103	¹³ C ₁₂ -2,3',4,4',5-PeCB ^{5,9}	118L	21:22	0.7613	0.7553-0.7672
2,3',4,5'-TeCB	67	¹³ C ₁₂ -3,3',4,4'-TeCB ^{4,5,9}	77L	21:38	0.8283	0.8251-0.8315
2,2',4,4',6'-PeCB	100	¹³ C ₁₂ -2,3',4,4',5-PeCB ^{5,9}	118L	21:41	0.7726	0.7666-0.7785
2,3,3',5'-TeCB	58	¹³ C ₁₂ -3,3',4,4'-TeCB ^{4,5,9}	77L	21:43	0.8315	0.8283-0.8347

Labeled or native CB ¹	IUPAC number ²	Retention time and quantitation references	IUPAC number	RT	RRT	RRT QC limits ³
2,3,4',5-TeCB	63	¹³ C ₁₂ -3,3',4,4'-TeCB ^{4,5,9}	77L	21:51	0.8366	0.8334-0.8398
2,2',3,5,6'-PeCB	94	¹³ C ₁₂ -2,3',4,4',5-PeCB ^{5,9}	118L	22:05	0.7868	0.7809-0.7928
2,4,4',5-TeCB	74	¹³ C ₁₂ -3,3',4,4'-TeCB ^{4,5,9}	77L	22:07	0.8468	0.8437-0.8500
2,3,4,5-TeCB	61	¹³ C ₁₂ -3,3',4,4'-TeCB ^{4,5,9}	77L	22:11	0.8494	0.8462-0.8526
2,3',4',5-TeCB	70	¹³ C ₁₂ -3,3',4,4'-TeCB ^{4,5,9}	77L	22:20	0.8551	0.8519-0.8583
2',3,4,5-TeCB	76	¹³ C ₁₂ -3,3',4,4'-TeCB ^{4,5,9}	77L	22:25	0.8583	0.8551-0.8615
2,2',3',4,6-PeCB	98	¹³ C ₁₂ -2,3',4,4',5-PeCB ^{5,9}	118L	22:28	0.8005	0.7975-0.8034
2,3',4,4'-TeCB ⁶	66	¹³ C ₁₂ -3,3',4,4'-TeCB ^{4,5,9}	77L	22:29	0.8609	0.8577-0.8641
2,2',4,5,6'-PeCB	102	¹³ C ₁₂ -2,3',4,4',5-PeCB ^{5,9}	118L	22:32	0.8029	0.7999-0.8058
2,2',3,5',6-PeCB	95	¹³ C ₁₂ -2,3',4,4',5-PeCB ^{5,9}	118L	22:34	0.8040	0.8011-0.8070
2,2',3,5,6-PeCB	93	¹³ C ₁₂ -2,3',4,4',5-PeCB ^{5,9}	118L	22:36	0.8052	0.8023-0.8082
3,3',5,5'-TeCB	80	¹³ C ₁₂ -3,3',4,4'-TeCB ^{4,5,9}	77L	22:45	0.8711	0.8679-0.8743
2,2',3,4,6-PeCB	88	¹³ C ₁₂ -2,3',4,4',5-PeCB ^{5,9}	118L	22:49	0.8129	0.8100-0.8159
2,2',3,4',6-PeCB	91	¹³ C ₁₂ -2,3',4,4',5-PeCB ^{5,9}	118L	22:55	0.8165	0.8135-0.8195
2,3,3',4'-TeCB	55	¹³ C ₁₂ -3,3',4,4'-TeCB ^{4,5,9}	77L	22:57	0.8787	0.8756-0.8819
2,3',4,5',6-PeCB	121	¹³ C ₁₂ -2,3',4,4',5-PeCB ^{5,9}	118L	23:04	0.8219	0.8189-0.8248
2,3,3',4'-TeCB	56	¹³ C ₁₂ -3,3',4,4'-TeCB ^{4,5,9}	77L	23:24	0.8960	0.8928-0.8992
2,3,4,4'-TeCB	60	¹³ C ₁₂ -3,3',4,4'-TeCB ^{4,5,9}	77L	23:24	0.8960	0.8928-0.8992
¹³ C ₁₂ -2,2',4,4',6,6'-HxCB ⁴	155L	¹³ C ₁₂ -2,3',4,4',5,5'-HxCB ^{5,9}	167L	23:43	0.7104	0.7054-0.7154
2,2',4,4',6,6'-HxCB	155	¹³ C ₁₂ -2,2',4,4',6,6'-HxCB ⁴	155L	23:43	1.0000	0.9986-1.0028
2,2',3,3',6-PeCB	84	¹³ C ₁₂ -2,3',4,4',5-PeCB ^{5,9}	118L	23:44	0.8456	0.8426-0.8486
2,2',3,5,5'-PeCB	92	¹³ C ₁₂ -2,3',4,4',5-PeCB ^{5,9}	118L	23:50	0.8492	0.8462-0.8521
2,2',3,4,6'-PeCB	89	¹³ C ₁₂ -2,3',4,4',5-PeCB ^{5,9}	118L	23:53	0.8510	0.8480-0.8539
2,2',3,4',5-PeCB	90	¹³ C ₁₂ -2,3',4,4',5-PeCB ^{5,9}	118L	24:07	0.8593	0.8563-0.8622
¹³ C ₁₂ -2,2',4,5,5'-PeCB ⁷	101L	¹³ C ₁₂ -2,2',4,5,5'-PeCB ⁷	101L	24:11	1.0000	0.9966-1.0034
2,2',4,5,5'-PeCB ⁶	101	¹³ C ₁₂ -2,3',4,4',5-PeCB ^{5,9}	118L	24:11	0.8616	0.8587-0.8646
2,3,3',5',6-PeCB	113	¹³ C ₁₂ -2,3',4,4',5-PeCB ^{5,9}	118L	24:23	0.8688	0.8658-0.8717
3,3',4,5'-TeCB	79	¹³ C ₁₂ -3,3',4,4'-TeCB ^{4,5,9}	77L	24:27	0.9362	0.9330-0.9394

Method 1668, Revision A

Labeled or native CB ¹	IUPAC number ²	Retention time and quantitation references	IUPAC number	RT	RRT	RRT QC limits ³
2,2',4,4',5-PeCB	99	¹³ C ₁₂ -2,3',4,4',5-PeCB ^{5,9}	118L	24:28	0.8717	0.8688-0.8747
2,2',3,4',6,6'-HxCB	150	¹³ C ₁₂ -2,3',4,4',5,5'-HxCB ^{5,9}	167L	24:52	0.7449	0.7399-0.7499
2,3',4,4',6-PeCB	119	¹³ C ₁₂ -2,3',4,4',5-PeCB ^{5,9}	118L	24:54	0.8872	0.8842-0.8901
2,3,3',5,6-PeCB	112	¹³ C ₁₂ -2,3',4,4',5-PeCB ^{5,9}	118L	25:00	0.8907	0.8878-0.8937
2,3,3',4,5'-PeCB	108	¹³ C ₁₂ -2,3',4,4',5-PeCB ^{5,9}	118L	25:09	0.8961	0.8931-0.8990
2,2',3,5,6,6'-HxCB	152	¹³ C ₁₂ -2,3',4,4',5,5'-HxCB ^{5,9}	167L	25:17	0.7574	0.7524-0.7624
2,2',3,3',5-PeCB	83	¹³ C ₁₂ -2,3',4,4',5-PeCB ^{5,9}	118L	25:20	0.8919	0.8890-0.8949
2,2',3',4,5-PeCB	97	¹³ C ₁₂ -2,3',4,4',5-PeCB ^{5,9}	118L	25:22	0.9038	0.9008-0.9068
2,2',3,4,5-PeCB	86	¹³ C ₁₂ -2,3',4,4',5-PeCB ^{5,9}	118L	25:27	0.9068	0.9038-0.9097
¹³ C ₁₂ -3,4,4',5-TeCB ⁹	81L	¹³ C ₁₂ -2,2',5,5'-TeCB ⁷	52L	25:32	1.3546	1.3457-1.3634
3,4,4',5-TeCB ¹⁰	81	¹³ C ₁₂ -3,4,4',5-TeCB ^{4,5,9}	77L	25:32	1.0000	0.9987-1.0026
2',3,4,5,6'-PeCB	125	¹³ C ₁₂ -2,3',4,4',5-PeCB ^{5,9}	118L	25:36	0.9121	0.9091-0.9151
2,3,4',5,6-PeCB	117	¹³ C ₁₂ -2,3',4,4',5-PeCB ^{5,9}	118L	25:37	0.9127	0.9097-0.9157
2,2',3,4,5'-PeCB	87	¹³ C ₁₂ -2,3',4,4',5-PeCB ^{5,9}	118L	25:38	0.9133	0.9103-0.9163
3,3',4,5-TeCB	78	¹³ C ₁₂ -3,3',4,4'-TeCB ^{4,5,9}	77L	25:40	0.9598	0.9566-0.9630
2,2',3,4,6,6'-HxCB	145	¹³ C ₁₂ -2,3',4,4',5,5'-HxCB ^{5,9}	167L	25:42	0.7698	0.7649-0.7748
2,3,4,4',6-PeCB	115	¹³ C ₁₂ -2,3',4,4',5-PeCB ^{5,9}	118L	25:44	0.9169	0.9139-0.9198
¹³ C ₁₂ -2,3,3',5,5'-PeCB ⁸	111L	¹³ C ₁₂ -2,2',4,5,5'-PeCB ⁷	101L	25:51	1.0689	1.0655-1.0724
2,3,3',5,5'-PeCB	111	¹³ C ₁₂ -2,3',4,4',5-PeCB ^{5,9}	118L	25:51	0.9210	0.9181-0.9240
2,2',3,4,4'-PeCB	85	¹³ C ₁₂ -2,3',4,4',5-PeCB ^{5,9}	118L	25:51	0.9210	0.9181-0.9240
2,3,4,5,6-PeCB	116	¹³ C ₁₂ -2,3',4,4',5-PeCB ^{5,9}	118L	25:48	0.9192	0.9163-0.9222
¹³ C ₁₂ -3,3',4,4'-TeCB ^{4,5,9}	77L	¹³ C ₁₂ -2,2',5,5'-TeCB ⁷	52L	26:07	1.3855	1.3767-1.3943
3,3',4,4'-TeCB ^{6,10}	77	¹³ C ₁₂ -3,3',4,4'-TeCB ^{4,5,9}	77L	26:07	1.0000	0.9987-1.0026
2,2',3,3',6,6'-HxCB	136	¹³ C ₁₂ -2,3',4,4',5,5'-HxCB ^{5,9}	167L	26:10	0.7793	0.7743-0.7843
2,3',4,5,5'-PeCB	120	¹³ C ₁₂ -2,3',4,4',5-PeCB ^{5,9}	118L	26:12	0.9335	0.9305-0.9365
2,2',3,4',5,6'-HxCB	148	¹³ C ₁₂ -2,3',4,4',5,5'-HxCB ^{5,9}	167L	26:14	0.7858	0.7808-0.7908
2,3,3',4',6-PeCB	110	¹³ C ₁₂ -2,3',4,4',5-PeCB ^{5,9}	118L	26:16	0.9359	0.9329-0.9388
2,2',4,4',5,6'-HxCB	154	¹³ C ₁₂ -2,3',4,4',5,5'-HxCB ^{5,9}	167L	26:44	0.8008	0.7983-0.8033

Labeled or native CB ¹	IUPAC number ²	Retention time and quantitation references	IUPAC number	RT	RRT	RRT QC limits ³
2,2',3,3',4-PeCB	82	¹³ C ₁₂ -2,3',4,4',5-PeCB ^{5,9}	118L	26:48	0.9549	0.9519-0.9578
2,2',3,5,5',6-HxCB	151	¹³ C ₁₂ -2,3',4,4',5,5'-HxCB ^{5,9}	167L	27:18	0.8178	0.8153-0.8203
2,2',3,3',5,6'-HxCB	135	¹³ C ₁₂ -2,3',4,4',5,5'-HxCB ^{5,9}	167L	27:31	0.8243	0.8218-0.8268
2',3,4,5,5'-PeCB	124	¹³ C ₁₂ -2,3',4,4',5-PeCB ^{5,9}	118L	27:36	0.9834	0.9804-0.9863
2,2',3,4,5',6-HxCB	144	¹³ C ₁₂ -2,3',4,4',5,5'-HxCB ^{5,9}	167L	27:38	0.8278	0.8253-0.8303
2,3,3',4',5-PeCB	107	¹³ C ₁₂ -2,3',4,4',5-PeCB ^{5,9}	118L	27:40	0.9857	0.9828-0.9887
2,2',3,4',5,6-HxCB	147	¹³ C ₁₂ -2,3',4,4',5,5'-HxCB ^{5,9}	167L	27:44	0.8308	0.8283-0.8333
2,3,3',4,6-PeCB	109	¹³ C ₁₂ -2,3',4,4',5-PeCB ^{5,9}	118L	27:45	0.9887	0.9857-0.9917
2,2',3,4',5',6-HxCB	149	¹³ C ₁₂ -2,3',4,4',5,5'-HxCB ^{5,9}	167L	28:01	0.8392	0.8367-0.8417
2,2',3,3',5,6-HxCB	134	¹³ C ₁₂ -2,3',4,4',5,5'-HxCB ^{5,9}	167L	28:35	0.8562	0.8537-0.8587
2,2',3,4,5,6'-HxCB	143	¹³ C ₁₂ -2,3',4,4',5,5'-HxCB ^{5,9}	167L	28:34	0.8557	0.8532-0.8582
¹³ C ₁₂ -2',3,4,4',5-PeCB ⁹	123L	¹³ C ₁₂ -2,2',4,5,5'-PeCB ⁷	101L	27:53	1.1530	1.1496-1.1564
2',3,4,4',5-PeCB ¹⁰	123	¹³ C ₁₂ -2',3,4,4',5-PeCB ⁹	123L	27:53	1.0000	0.9988-1.0024
2,2',3,4,4',6-HxCB	139	¹³ C ₁₂ -2,3',4,4',5,5'-HxCB ^{5,9}	167L	28:01	0.8392	0.8367-0.8417
2,3,3',4,5-PeCB	106	¹³ C ₁₂ -2,3',4,4',5-PeCB ^{5,9}	118L	28:04	1.0000	0.9970-1.0030
¹³ C ₁₂ -2,3',4,4',5-PeCB ^{5,9}	118L	¹³ C ₁₂ -2,2',4,5,5'-PeCB ⁷	101L	28:04	1.1606	1.1571-1.1640
2,3',4,4',5-PeCB ^{6,10}	118	¹³ C ₁₂ -2,3',4,4',5-PeCB ^{5,9}	118L	28:04	1.0000	0.9988-1.0024
2,2',3,4,4',6'-HxCB	140	¹³ C ₁₂ -2,3',4,4',5,5'-HxCB ^{5,9}	167L	28:12	0.8447	0.8422-0.8472
¹³ C ₁₂ -2,3,4,4',5-PeCB ⁹	114L	¹³ C ₁₂ -2,2',4,5,5'-PeCB ⁷	101L	28:38	1.1840	1.1806-1.1875
2,3,4,4',5-PeCB ¹⁰	114	¹³ C ₁₂ -2,3,4,4',5-PeCB ⁹	114L	28:38	1.0000	0.9988-1.0023
2',3,3',4,5-PeCB	122	¹³ C ₁₂ -2,3',4,4',5-PeCB ^{5,9}	118L	28:48	1.0261	1.0232-1.0291
2,2',3,3',4,6-HxCB	131	¹³ C ₁₂ -2,3',4,4',5,5'-HxCB ^{5,9}	167L	28:52	0.8647	0.8622-0.8672
2,2',3,4,5,6-HxCB	142	¹³ C ₁₂ -2,3',4,4',5,5'-HxCB ^{5,9}	167L	28:59	0.8682	0.8657-0.8707
2,2',3,3',5,5'-HxCB	133	¹³ C ₁₂ -2,3',4,4',5,5'-HxCB ^{5,9}	167L	28:59	0.8682	0.8657-0.8707
2,2',3,3',4,6'-HxCB	132	¹³ C ₁₂ -2,3',4,4',5,5'-HxCB ^{5,9}	167L	29:32	0.8847	0.8822-0.8872
2,3,3',5,5',6-HxCB	165	¹³ C ₁₂ -2,3',4,4',5,5'-HxCB ^{5,9}	167L	29:21	0.8792	0.8767-0.8817
¹³ C ₁₂ -2,2',3,4',5,6,6'-HpCB ⁴	188L	¹³ C ₁₂ -2',3,3',4,4',5,5'-HpCB ^{4,5,9}	189L	29:22	0.9511	0.7327-0.7411
2,2',3,4',5,6,6'-HpCB	188	¹³ C ₁₂ -2,2',3,4',5,6,6'-HpCB ⁴	188L	29:22	1.0000	0.9989-1.0023

Method 1668, Revision A

Labeled or native CB ¹	IUPAC number ²	Retention time and quantitation references	IUPAC number	RT	RRT	RRT QC limits ³
2,2',3,4',5,5'-HxCB	146	¹³ C ₁₂ -2,3',4,4',5,5'-HxCB ^{5,9}	167L	29:24	0.8807	0.8782-0.8832
¹³ C ₁₂ -2,3,3',4,4'-PeCB ⁹	105L	¹³ C ₁₂ -2,2',4,5,5'-PeCB ⁷	101L	29:30	1.2198	1.2130-1.2267
2,3,3',4,4'-PeCB ^{6,10}	105	¹³ C ₁₂ -2,3,3',4,4'-PeCB ⁹	105L	29:30	1.0000	0.9989-1.0023
2,3,3',4,5',6-HxCB	161	¹³ C ₁₂ -2,3',4,4',5,5'-HxCB ^{5,9}	167L	29:32	0.8847	0.8822-0.8872
2,2',4,4',5,5'-HxCB ⁶	153	¹³ C ₁₂ -2,3',4,4',5,5'-HxCB ^{5,9}	167L	29:48	0.8927	0.8902-0.8952
2,2',3,4,4',6,6'-HpCB	184	¹³ C ₁₂ -2',3,3',4,4',5,5'-HpCB ^{4,5,9}	189L	29:49	0.7482	0.7440-0.7524
3,3',4,5,5'-PeCB	127	¹³ C ₁₂ -2,3',4,4',5-PeCB ^{5,9}	118L	29:57	1.0671	1.0641-1.0701
2,3',4,4',5',6-HxCB	168	¹³ C ₁₂ -2,3',4,4',5,5'-HxCB ^{5,9}	167L	29:59	0.8982	0.8957-0.9006
2,2',3,4,5,5'-HxCB	141	¹³ C ₁₂ -2,3',4,4',5,5'-HxCB ^{5,9}	167L	30:31	0.9141	0.9116-0.9166
2,2',3,3',5,6,6'-HpCB	179	¹³ C ₁₂ -2',3,3',4,4',5,5'-HpCB ^{4,5,9}	189L	30:33	0.7666	0.7624-0.7708
2,2',3,4,4',5-HxCB	137	¹³ C ₁₂ -2,3',4,4',5,5'-HxCB ^{5,9}	167L	30:51	0.9241	0.9216-0.9266
2,2',3,3',4,5'-HxCB	130	¹³ C ₁₂ -2,3',4,4',5,5'-HxCB ^{5,9}	167L	30:57	0.9271	0.9246-0.9296
2,2',3,3',4,6,6'-HpCB	176	¹³ C ₁₂ -2',3,3',4,4',5,5'-HpCB ^{4,5,9}	189L	31:01	0.7783	0.7742-0.7825
¹³ C ₁₂ -2,2',3,4,4',5'-HxCB ⁷	138L	¹³ C ₁₂ -2,2',3,4,4',5'-HxCB ⁷	138L	31:20	1.0000	0.9973-1.0027
2,2',3,4,4',5'-HxCB ⁶	138	¹³ C ₁₂ -2,3',4,4',5,5'-HxCB ^{5,9}	167L	31:20	0.9386	0.9361-0.9411
2,3,3',4',5',6-HxCB	164	¹³ C ₁₂ -2,3',4,4',5,5'-HxCB ^{5,9}	167L	31:22	0.9396	0.9371-0.9421
2,3,3',4',5,6-HxCB	163	¹³ C ₁₂ -2,3',4,4',5,5'-HxCB ^{5,9}	167L	31:28	0.9426	0.9401-0.9451
2,3,3',4,5,6-HxCB	160	¹³ C ₁₂ -2,3',4,4',5,5'-HxCB ^{5,9}	167L	31:33	0.9451	0.9426-0.9476
2,3,3',4,4',6-HxCB	158	¹³ C ₁₂ -2,3',4,4',5,5'-HxCB ^{5,9}	167L	31:35	0.9461	0.9436-0.9486
2,2',3,4,5,6,6'-HpCB	186	¹³ C ₁₂ -2',3,3',4,4',5,5'-HpCB ^{4,5,9}	189L	31:36	0.7930	0.7888-0.7972
2,2',3,3',4,5-HxCB	129	¹³ C ₁₂ -2,3',4,4',5,5'-HxCB ^{5,9}	167L	31:48	0.9526	0.9501-0.9551
¹³ C ₁₂ -3,3',4,4',5-PeCB ^{4,9}	126L	¹³ C ₁₂ -2,2',4,5,5'-PeCB ⁷	101L	31:49	1.3156	1.3088-1.3225
3,3',4,4',5-PeCB ^{6,10}	126	¹³ C ₁₂ -3,3',4,4',5-PeCB ^{4,9}	126L	31:49	1.0000	0.9990-1.0021
2,3,4,4',5,6-HxCB	166	¹³ C ₁₂ -2,3',4,4',5,5'-HxCB ^{5,9}	167L	32:13	0.9651	0.9626-0.9675
¹³ C ₁₂ -2,2',3,3',5,5',6-HpCB ⁷	178L	¹³ C ₁₂ -2,2',3,3',5,5',6-HpCB ⁷	178L	32:14	1.0000	0.9974-1.0026
2,2',3,3',5,5',6-HpCB	178	¹³ C ₁₂ -2',3,3',4,4',5,5'-HpCB ^{4,5,9}	189L	32:14	0.8089	0.8068-0.8110
2,2',3,3',4,5',6-HpCB	175	¹³ C ₁₂ -2',3,3',4,4',5,5'-HpCB ^{4,5,9}	189L	32:33	0.8168	0.8147-0.8189
2,3,3',4,5,5'-HxCB	159	¹³ C ₁₂ -2,3',4,4',5,5'-HxCB ^{5,9}	167L	32:43	0.9800	0.9775-0.9825

Labeled or native CB ¹	IUPAC number ²	Retention time and quantitation references	IUPAC number	RT	RRT	RRT QC limits ³
2,2',3,4',5,5',6-HpCB ⁶	187	¹³ C ₁₂ -2',3,3',4,4',5,5'-HpCB ^{4,5,9}	189L	32:46	0.8223	0.8202-0.8243
2,2',3,4,4',5,6'-HpCB	182	¹³ C ₁₂ -2',3,3',4,4',5,5'-HpCB ^{4,5,9}	189L	32:47	0.8227	0.8206-0.8248
2,2',3,3',4,4'-HxCB ⁶	128	¹³ C ₁₂ -2,3',4,4',5,5'-HxCB ^{5,9}	167L	32:52	0.9845	0.9820-0.9870
2,3,3',4',5,5'-HxCB	162	¹³ C ₁₂ -2,3',4,4',5,5'-HxCB ^{5,9}	167L	33:00	0.9885	0.9860-0.9910
2,2',3,4,4',5',6-HpCB	183	¹³ C ₁₂ -2',3,3',4,4',5,5'-HpCB ^{4,5,9}	189L	33:06	0.8306	0.8285-0.8327
¹³ C ₁₂ -2,3',4,4',5,5'-HxCB ^{5,9}	167L	¹³ C ₁₂ -2,2',3,4,4',5'-HxCB ⁷	138L	33:23	1.0654	1.0628-1.0681
2,3',4,4',5,5'-HxCB ¹⁰	167	¹³ C ₁₂ -2,3',4,4',5,5'-HxCB ^{5,9}	167L	33:23	1.0000	0.9990-1.0020
2,2',3,4,5,5',6-HpCB	185	¹³ C ₁₂ -2',3,3',4,4',5,5'-HpCB ^{4,5,9}	189L	33:43	0.8461	0.8440-0.8482
2,2',3,3',4,5,6'-HpCB	174	¹³ C ₁₂ -2',3,3',4,4',5,5'-HpCB ^{4,5,9}	189L	34:07	0.8561	0.8540-0.8582
2,2',3,4,4',5,6-HpCB	181	¹³ C ₁₂ -2',3,3',4,4',5,5'-HpCB ^{4,5,9}	189L	34:11	0.8578	0.8557-0.8599
2,2',3,3',4',5,6-HpCB	177	¹³ C ₁₂ -2',3,3',4,4',5,5'-HpCB ^{4,5,9}	189L	34:22	0.8624	0.8603-0.8645
2,2',3,3',4,4',6-HpCB	171	¹³ C ₁₂ -2',3,3',4,4',5,5'-HpCB ^{4,5,9}	189L	34:40	0.8699	0.8678-0.8720
¹³ C ₁₂ -2,3,3',4,4',5'-HxCB ⁹	156L	¹³ C ₁₂ -2,2',3,4,4',5'-HxCB ⁷	138L	34:40	1.1064	1.1037-1.1090
2,3,3',4,4',5-HxCB ¹⁰	156	¹³ C ₁₂ -2,3,3',4,4',5'-HxCB ⁹	156L	34:40	1.0000	0.9990-1.0019
¹³ C ₁₂ -2,2',3,3',5,5',6,6'-OxCB ⁴	202L	¹³ C ₁₂ -Cl8-PCB-194 ⁵	194L	34:56	0.8265	0.8245-0.8285
2,2',3,3',5,5',6,6'-OxCB	202	¹³ C ₁₂ -2,2',3,3',5,5',6,6'-OxCB ⁴	202L	34:56	1.0000	0.9990-1.0019
¹³ C ₁₂ -2,3,3',4,4',5'-HxCB ⁹	157L	¹³ C ₁₂ -2,2',3,4,4',5'-HxCB ⁷	138L	34:57	1.1154	1.1128-1.1181
2,3,3',4,4',5'-HxCB ¹⁰	157	¹³ C ₁₂ -2,3,3',4,4',5'-HxCB ⁹	157L	34:57	1.0000	0.9990-1.0019
2,2',3,3',4,5,6-HpCB	173	¹³ C ₁₂ -2',3,3',4,4',5,5'-HpCB ^{4,5,9}	189L	35:04	0.8800	0.8779-0.8821
2,2',3,3',4,5,6'-OxCB	201	¹³ C ₁₂ -Cl8-PCB-194 ⁵	194L	35:25	0.8379	0.8360-0.8399
2,2',3,4,4',5,6,6'-OxCB	204	¹³ C ₁₂ -Cl8-PCB-194 ⁵	194L	35:36	0.8423	0.8403-0.8442
2,2',3,3',4,5,5'-HpCB	172	¹³ C ₁₂ -2',3,3',4,4',5,5'-HpCB ^{4,5,9}	189L	35:41	0.8954	0.8934-0.8975
2,3,3',4,5,5',6-HpCB	192	¹³ C ₁₂ -2',3,3',4,4',5,5'-HpCB ^{4,5,9}	189L	35:51	0.8996	0.8975-0.9017
2,2',3,3',4,4',6,6'-OxCB	197	¹³ C ₁₂ -Cl8-PCB-194 ⁵	194L	35:55	0.8498	0.8478-0.8517
2,2',3,4,4',5,5'-HpCB ⁶	180	¹³ C ₁₂ -2',3,3',4,4',5,5'-HpCB ^{4,5,9}	189L	36:07	0.9063	0.9042-0.9084
2,3,3',4',5,5',6-HpCB	193	¹³ C ₁₂ -2',3,3',4,4',5,5'-HpCB ^{4,5,9}	189L	36:20	0.9118	0.9097-0.9138
2,3,3',4,4',5',6-HpCB	191	¹³ C ₁₂ -2',3,3',4,4',5,5'-HpCB ^{4,5,9}	189L	36:34	0.9176	0.9155-0.9197
2,2',3,3',4,5,6,6'-OxCB	200	¹³ C ₁₂ -Cl8-PCB-194 ⁵	194L	36:49	0.8711	0.8691-0.8730

Labeled or native CB ¹	IUPAC number ²	Retention time and quantitation references	IUPAC number	RT	RRT	RRT QC limits ³
¹³ C ₁₂ -3,3',4,4',5,5'-HxCB ^{4,9}	169L	¹³ C ₁₂ -2,2',3,4,4',5'-HxCB ⁷	138L	37:19	1.1910	1.1883-1.1936
3,3',4,4',5,5'-HxCB ^{6,10}	169	¹³ C ₁₂ -3,3',4,4',5,5'-HxCB ^{4,9}	169L	37:19	1.0000	0.9991-1.0018
2,2',3,3',4,4',5-HpCB ⁶	170	¹³ C ₁₂ -2',3,3',4,4',5,5'-HpCB ^{4,5,9}	189L	37:44	0.9469	0.9448-0.9490
2,3,3',4,4',5,6-HpCB	190	¹³ C ₁₂ -2',3,3',4,4',5,5'-HpCB ^{4,5,9}	189L	37:56	0.9519	0.9498-0.9540
2,2',3,3',4,5,5',6-OcCB	198	¹³ C ₁₂ -Cl8-PCB-194 ⁵	194L	38:34	0.9125	0.9105-0.9144
2,2',3,3',4,5,5',6'-OcCB	199	¹³ C ₁₂ -Cl8-PCB-194 ⁵	194L	38:43	0.9160	0.9140-0.9180
2,2',3,3',4,4',5,6'-OcCB	196	¹³ C ₁₂ -Cl8-PCB-194 ⁵	194L	39:05	0.9247	0.9227-0.9267
2,2',3,4,4',5,5',6-OcCB	203	¹³ C ₁₂ -Cl8-PCB-194 ⁵	194L	39:05	0.9247	0.9227-0.9267
¹³ C ₁₂ -2',3,3',4,4',5,5'-HpCB ^{4,5,9}	189L	¹³ C ₁₂ -2,2',3,3',5,5',6-HpCB ⁷	178L	39:51	1.2363	1.2311-1.2415
2,3,3',4,4',5,5'-HpCB ¹⁰	189	¹³ C ₁₂ -2',3,3',4,4',5,5'-HpCB ^{4,5,9}	189L	39:51	1.0000	0.9992-1.0017
2,2',3,3',4,4',5,6-OcCB ⁶	195	¹³ C ₁₂ -Cl8-PCB-194 ⁵	194L	40:45	0.9641	0.9621-0.9661
¹³ C ₁₂ -2,2',3,3',4,5,5',6,6'-NoCB ⁴	208L	¹³ C ₁₂ -Cl9-PCB-206 ^{4,5}	206L	41:03	0.9149	0.9131-0.9168
2,2',3,3',4,5,5',6,6'-NoCB	208	¹³ C ₁₂ -2,2',3,3',4,5,5',6,6'-NoCB ⁴	208L	41:03	1.0000	0.9992-1.0016
2,2',3,3',4,4',5,6,6'-NoCB	207	¹³ C ₁₂ -Cl9-PCB-206 ^{4,5}	206L	41:32	0.9257	0.9238-0.9276
¹³ C ₁₂ -2,2',3,3',4,4',5,5'-OcCB ⁵	194L	¹³ C ₁₂ -2,2',3,3',5,5',6-HpCB ⁷	178L	42:16	1.3113	1.3061-1.3164
2,2',3,3',4,4',5,5'-OcCB	194	¹³ C ₁₂ -Cl8-PCB-194 ⁵	194L	42:16	1.0000	0.9992-1.0016
¹³ C ₁₂ -2,3,3',4,4',5,5',6-OcCB ⁴	205L	¹³ C ₁₂ -Cl8-PCB-194 ⁵	194L	42:44	1.0110	1.0091-1.0130
2,3,3',4,4',5,5',6-OcCB	205	¹³ C ₁₂ -2,3,3',4,4',5,5',6-OcCB ⁴	205L	42:44	1.0000	0.9992-1.0016
¹³ C ₁₂ -2,2',3,3',4,4',5,5',6-NoCB ^{4,5}	206L	¹³ C ₁₂ -2,2',3,3',5,5',6-HpCB ⁷	178L	44:52	1.3919	1.3868-1.3971
2,2',3,3',4,4',5,5',6-NoCB ⁶	206	¹³ C ₁₂ -Cl9-PCB-206 ^{4,5}	206L	44:52	1.0000	0.9993-1.0015
¹³ C ₁₂ -2,2',3,3',4,4',5,5',6,6'-DeCB ^{4,5}	209L	¹³ C ₁₂ -2,2',3,3',5,5',6-HpCB ⁷	178L	46:55	1.4555	1.4504-1.4607
2,2',3,3',4,4',5,5',6,6'-DeCB ⁶	209	¹³ C ₁₂ -Cl10-PCB-209 ^{4,5}	209L	46:55	1.0000	0.9993-1.0014

- Abbreviations for chlorination levels
 MoCB = monochlorobiphenyl
 DiCB = dichlorobiphenyl
 TrCB = trichlorobiphenyl
 TeCB = tetrachlorobiphenyl
 PeCB = pentachlorobiphenyl
 HxCB = hexachlorobiphenyl

HpCB = heptachlorobiphenyl
OcCB = octachlorobiphenyl
NoCB = nonachlorobiphenyl
DeCB = decachlorobiphenyl

2. Suffix "L" indicates labeled compound.
3. For native CBs determined by isotope dilution quantitation, RRT QC limits were constructed using -2 to +4 seconds around the the retention time for the labeled analog. For native CBs determined by internal standard quantitation, RRT QC limits were constructed using a ± 2 percent window around the retention time for retention times in the range of 0.8-1.2 and a ± 4 percent window around the retention time for retention times <0.8 and >1.2 . These windows may not be adequate for analyte identification (See the note in Section 16.4)
4. Labeled level of chlorination (LOC) window-defining congener
5. Labeled level of chlorination (LOC) quantitation congener
6. National Oceanic and Atmospheric Administration (NOAA) congener of interest
7. Instrument internal standard
8. Clean-up standard
9. Labeled internal standard for World Health Organization (WHO) toxic congener
10. WHO toxic congener

Table A-2 Scan descriptors, levels of chlorination, m/z information, and substances monitored by HRGC/HRMS

Function and chlorine level	m/z	m/z type	m/z formula	Substance
Fn-1	188.0393	M	$^{12}\text{C}_{12}\text{H}_9\text{ }^{35}\text{Cl}$	Cl-1 PCB
Cl-1	190.0363	M+2	$^{12}\text{C}_{12}\text{H}_9\text{ }^{37}\text{Cl}$	Cl-1P CB
	200.0795	M	$^{13}\text{C}_{12}\text{H}_9\text{ }^{35}\text{Cl}$	$^{13}\text{C}_{12}$ Cl-1 PCB
	202.0766	M+2	$^{13}\text{C}_{12}\text{H}_9\text{ }^{37}\text{Cl}$	$^{13}\text{C}_{12}$ Cl-1 PCB
	218.9856	lock	C_4F_9	PFK
Fn-2	222.0003	M	$^{12}\text{C}_{12}\text{H}_8\text{ }^{35}\text{Cl}_2$	Cl-2 PCB
Cl-2,3	223.9974	M+2	$^{12}\text{C}_{12}\text{H}_8\text{ }^{35}\text{Cl}\text{ }^{37}\text{Cl}$	Cl-2 PCB
	225.9944	M+4	$^{12}\text{C}_{12}\text{H}_8\text{ }^{37}\text{Cl}_2$	Cl-2 PCB
	234.0406	M	$^{13}\text{C}_{12}\text{H}_8\text{ }^{35}\text{Cl}_2$	$^{13}\text{C}_{12}$ Cl-2 PCB
	236.0376	M+2	$^{13}\text{C}_{12}\text{H}_8\text{ }^{35}\text{Cl}\text{ }^{37}\text{Cl}$	$^{13}\text{C}_{12}$ Cl-2 PCB
	242.9856	lock	C_6F_9	PFK
	255.9613	M	$^{12}\text{C}_{12}\text{H}_7\text{ }^{35}\text{Cl}_3$	Cl-3 PCB
	257.9584	M+2	$^{12}\text{C}_{12}\text{H}_7\text{ }^{35}\text{Cl}_2\text{ }^{37}\text{Cl}$	Cl-3 PCB
Fn-3	255.9613	M	$^{12}\text{C}_{12}\text{H}_7\text{ }^{35}\text{Cl}_3$	Cl-3 PCB
Cl-3,4,5	257.9584	M+2	$^{12}\text{C}_{12}\text{H}_7\text{ }^{35}\text{Cl}_2\text{ }^{37}\text{Cl}$	Cl-3 PCB
	259.9554	M+4	$^{12}\text{C}_{12}\text{H}_7\text{ }^{35}\text{Cl}\text{ }^{37}\text{Cl}_2$	Cl-3 PCB
	268.0016	M	$^{13}\text{C}_{12}\text{H}_7\text{ }^{35}\text{Cl}_3$	$^{13}\text{C}_{12}$ Cl-3 PCB
	269.9986	M+2	$^{13}\text{C}_{12}\text{H}_7\text{ }^{35}\text{Cl}_2\text{ }^{37}\text{Cl}$	$^{13}\text{C}_{12}$ Cl-3 PCB
	280.9825	lock	C_6F_{11}	PFK
	289.9224	M	$^{12}\text{C}_{12}\text{H}_6\text{ }^{35}\text{Cl}_4$	Cl-4 PCB
	291.9194	M+2	$^{12}\text{C}_{12}\text{H}_6\text{ }^{35}\text{Cl}_3\text{ }^{37}\text{Cl}$	Cl-4 PCB
	293.9165	M+4	$^{12}\text{C}_{12}\text{H}_6\text{ }^{35}\text{Cl}_2\text{ }^{37}\text{Cl}_2$	Cl-4 PCB
	301.9626	M	$^{13}\text{C}_{12}\text{H}_6\text{ }^{35}\text{Cl}_4$	$^{13}\text{C}_{12}$ Cl-4 PCB
	303.9597	M+2	$^{13}\text{C}_{12}\text{H}_6\text{ }^{35}\text{Cl}_3\text{ }^{37}\text{Cl}$	$^{13}\text{C}_{12}$ Cl-4 PCB
	323.8834	M	$^{12}\text{C}_{12}\text{H}_5\text{ }^{35}\text{Cl}_5$	Cl-5 PCB

Function and chlorine level	m/z	m/z type	m/z formula	Substance
	325.8804	M+2	$^{12}\text{C}_{12}\text{H}_5\text{ }^{35}\text{Cl}_4\text{ }^{37}\text{Cl}$	CI-5 PCB
	327.8775	M+4	$^{12}\text{C}_{12}\text{H}_5\text{ }^{35}\text{Cl}_3\text{ }^{37}\text{Cl}_2$	CI-5 PCB
	337.9207	M+2	$^{13}\text{C}_{12}\text{H}_5\text{ }^{35}\text{Cl}_4\text{ }^{37}\text{Cl}$	$^{13}\text{C}_{12}$ CI-5 PCB
	339.9178	M+4	$^{13}\text{C}_{12}\text{H}_5\text{ }^{35}\text{Cl}_3\text{ }^{37}\text{Cl}_2$	$^{13}\text{C}_{12}$ CI-5 PCB
Fn-4	289.9224	M	$^{12}\text{C}_{12}\text{H}_6\text{ }^{35}\text{Cl}_4$	CI-4 PCB
CI-4,5,6	291.9194	M+2	$^{12}\text{C}_{12}\text{H}_6\text{ }^{35}\text{Cl}_3\text{ }^{37}\text{Cl}$	CI-4 PCB
	293.9165	M+4	$^{12}\text{C}_{12}\text{H}_6\text{ }^{35}\text{Cl}_2\text{ }^{37}\text{Cl}_2$	CI-4 PCB
	301.9626	M+2	$^{13}\text{C}_{12}\text{H}_6\text{ }^{35}\text{Cl}_3\text{ }^{37}\text{Cl}$	$^{13}\text{C}_{12}$ CI-4 PCB
	303.9597	M+4	$^{13}\text{C}_{12}\text{H}_6\text{ }^{35}\text{Cl}_2\text{ }^{37}\text{Cl}_2$	$^{13}\text{C}_{12}$ CI-4 PCB
	323.8834	M	$^{12}\text{C}_{12}\text{H}_5\text{ }^{35}\text{Cl}_5$	CI-5 PCB
	325.8804	M+2	$^{12}\text{C}_{12}\text{H}_5\text{ }^{35}\text{Cl}_4\text{ }^{37}\text{Cl}$	CI-5 PCB
	327.8775	M+4	$^{12}\text{C}_{12}\text{H}_5\text{ }^{35}\text{Cl}_3\text{ }^{37}\text{Cl}_2$	CI-5 PCB
	330.9792	lock	C_7F_{15}	PFK
	337.9207	M+2	$^{13}\text{C}_{12}\text{H}_5\text{ }^{35}\text{Cl}_4\text{ }^{37}\text{Cl}$	$^{13}\text{C}_{12}$ CI-5 PCB
	339.9178	M+4	$^{13}\text{C}_{12}\text{H}_5\text{ }^{35}\text{Cl}_3\text{ }^{37}\text{Cl}_2$	$^{13}\text{C}_{12}$ CI-5 PCB
	359.8415	M+2	$^{13}\text{C}_{12}\text{H}_4\text{ }^{35}\text{Cl}_5\text{ }^{37}\text{Cl}$	CI-6 PCB
	361.8385	M+4	$^{13}\text{C}_{12}\text{H}_4\text{ }^{35}\text{Cl}_4\text{ }^{37}\text{Cl}_2$	CI-6 PCB
	363.8356	M+6	$^{13}\text{C}_{12}\text{H}_4\text{ }^{35}\text{Cl}_3\text{ }^{37}\text{Cl}_2$	CI-6 PCB
	371.8817	M+2	$^{13}\text{C}_{12}\text{H}_4\text{ }^{35}\text{Cl}_5\text{ }^{37}\text{Cl}$	$^{13}\text{C}_{12}$ CI-6 PCB
	373.8788	M+4	$^{13}\text{C}_{12}\text{H}_4\text{ }^{35}\text{Cl}_4\text{ }^{37}\text{Cl}_2$	$^{13}\text{C}_{12}$ CI-6 PCB
Fn-5	323.8834	M	$^{12}\text{C}_{12}\text{H}_5\text{ }^{35}\text{Cl}_5$	CI-5 PCB
CI-5,6,7,8	325.8804	M+2	$^{12}\text{C}_{12}\text{H}_5\text{ }^{35}\text{Cl}_4\text{ }^{37}\text{Cl}$	CI-5 PCB
	327.8775	M+4	$^{12}\text{C}_{12}\text{H}_5\text{ }^{35}\text{Cl}_3\text{ }^{37}\text{Cl}_2$	CI-5 PCB
	337.9207	M+2	$^{13}\text{C}_{12}\text{H}_5\text{ }^{35}\text{Cl}_4\text{ }^{37}\text{Cl}$	$^{13}\text{C}_{12}$ CI-5 PCB
	339.9178	M+4	$^{13}\text{C}_{12}\text{H}_5\text{ }^{35}\text{Cl}_3\text{ }^{37}\text{Cl}_2$	$^{13}\text{C}_{12}$ CI-5 PCB
	354.9792	lock	C_9F_{13}	PFK
	359.8415	M+2	$^{12}\text{C}_{12}\text{H}_4\text{ }^{35}\text{Cl}_5\text{ }^{37}\text{Cl}$	CI-6 PCB
	361.8385	M+4	$^{12}\text{C}_{12}\text{H}_4\text{ }^{35}\text{Cl}_4\text{ }^{37}\text{Cl}_2$	CI-6 PCB

Method 1668, Revision A

Function and chlorine level	m/z	m/z type	m/z formula	Substance
	363.8356	M+6	$^{12}\text{C}_{12}\text{H}_4\text{ }^{35}\text{Cl}_3\text{ }^{37}\text{Cl}_3$	CI-6 PCB
	371.8817	M+2	$^{13}\text{C}_{12}\text{H}_4\text{ }^{35}\text{Cl}_5\text{ }^{37}\text{Cl}$	$^{13}\text{C}_{12}$ CI-6 PCB
	373.8788	M+4	$^{13}\text{C}_{12}\text{H}_4\text{ }^{35}\text{Cl}_4\text{ }^{37}\text{Cl}_2$	$^{13}\text{C}_{12}$ CI-6 PCB
	393.8025	M+2	$^{12}\text{C}_{12}\text{H}_3\text{ }^{35}\text{Cl}_6\text{ }^{37}\text{Cl}$	CI-7 PCB
	395.7995	M+4	$^{12}\text{C}_{12}\text{H}_3\text{ }^{35}\text{Cl}_5\text{ }^{37}\text{Cl}_2$	CI-7 PCB
	397.7966	M+6	$^{12}\text{C}_{12}\text{H}_3\text{ }^{35}\text{Cl}_4\text{ }^{37}\text{Cl}_3$	CI-7 PCB
	405.8428	M+2	$^{13}\text{C}_{12}\text{H}_3\text{ }^{35}\text{Cl}_6\text{ }^{37}\text{Cl}$	$^{13}\text{C}_{12}$ CI-7 PCB
	407.8398	M+4	$^{13}\text{C}_{12}\text{H}_3\text{ }^{35}\text{Cl}_5\text{ }^{37}\text{Cl}_2$	$^{13}\text{C}_{12}$ CI-7 PCB
	427.7635	M+2	$^{12}\text{C}_{12}\text{H}_2\text{ }^{35}\text{Cl}_7\text{ }^{37}\text{Cl}$	CI-8 PCB
	429.7606	M+4	$^{12}\text{C}_{12}\text{H}_2\text{ }^{35}\text{Cl}_6\text{ }^{37}\text{Cl}_2$	CI-8 PCB
	431.7576	M+6	$^{12}\text{C}_{12}\text{H}_2\text{ }^{35}\text{Cl}_5\text{ }^{37}\text{Cl}_3$	CI-8 PCB
	439.8038	M+2	$^{13}\text{C}_{12}\text{H}_2\text{ }^{35}\text{Cl}_7\text{ }^{37}\text{Cl}$	$^{13}\text{C}_{12}$ CI-8 PCB
	441.8008	M+4	$^{13}\text{C}_{12}\text{H}_2\text{ }^{35}\text{Cl}_6\text{ }^{37}\text{Cl}_2$	$^{13}\text{C}_{12}$ CI-8 PCB
	454.9728	QC	$\text{C}_{11}\text{F}_{17}$	PFK
Fn-6	427.7635	M+2	$^{12}\text{C}_{12}\text{H}_2\text{ }^{35}\text{Cl}_7\text{ }^{37}\text{Cl}$	CI-8 PCB
CI-8,9,10	429.7606	M+4	$^{12}\text{C}_{12}\text{H}_2\text{ }^{35}\text{Cl}_6\text{ }^{37}\text{Cl}_2$	CI-8 PCB
	431.7576	M+6	$^{12}\text{C}_{12}\text{H}_2\text{ }^{35}\text{Cl}_5\text{ }^{37}\text{Cl}_3$	CI-8 PCB
	439.8038	M+2	$^{13}\text{C}_{12}\text{H}_2\text{ }^{35}\text{Cl}_7\text{ }^{37}\text{Cl}$	$^{13}\text{C}_{12}$ CI-8 PCB
	441.8008	M+4	$^{13}\text{C}_{12}\text{H}_2\text{ }^{35}\text{Cl}_6\text{ }^{37}\text{Cl}_2$	$^{13}\text{C}_{12}$ CI-8 PCB
	442.9728	QC	$\text{C}_{10}\text{F}_{13}$	PFK
	454.9728	lock	$\text{C}_{11}\text{F}_{13}$	PFK
	461.7246	M+2	$^{12}\text{C}_{12}\text{H}_1\text{ }^{35}\text{Cl}_8\text{ }^{37}\text{Cl}$	CI-9 PCB
	463.7216	M+4	$^{12}\text{C}_{12}\text{H}_1\text{ }^{35}\text{Cl}_7\text{ }^{37}\text{Cl}_2$	CI-9 PCB
	465.7187	M+6	$^{12}\text{C}_{12}\text{H}_1\text{ }^{35}\text{Cl}_6\text{ }^{37}\text{Cl}_3$	CI-9 PCB
	473.7648	M+2	$^{13}\text{C}_{12}\text{H}_1\text{ }^{35}\text{Cl}_8\text{ }^{37}\text{Cl}$	$^{13}\text{C}_{12}$ CI-9 PCB
	475.7619	M+4	$^{13}\text{C}_{12}\text{H}_1\text{ }^{35}\text{Cl}_7\text{ }^{37}\text{Cl}_2$	$^{13}\text{C}_{12}$ CI-9 PCB
	495.6856	M+2	$^{13}\text{C}_{12}\text{H}_4\text{ }^{35}\text{Cl}_9\text{ }^{37}\text{Cl}$	CI-10 PCB
	499.6797	M+4	$^{12}\text{C}_{12}\text{ }^{35}\text{Cl}_7\text{ }^{37}\text{Cl}_3$	CI-10 PCB

Function and chlorine level	m/z	m/z type	m/z formula	Substance
	501.6767	M+6	$^{12}\text{C}_{12} \text{}^{35}\text{Cl}_6 \text{}^{37}\text{Cl}_4$	Cl-10 PCB
	507.7258	M+2	$^{13}\text{C}_{12} \text{H}_4 \text{}^{35}\text{Cl}_9 \text{}^{37}\text{Cl}$	$^{13}\text{C}_{12}$ Cl-10 PCB
	509.7229	M+4	$^{13}\text{C}_{12} \text{H}_4 \text{}^{35}\text{Cl}_8 \text{}^{37}\text{Cl}_2$	$^{13}\text{C}_{12}$ Cl-10 PCB
	511.7199	M+6	$^{13}\text{C}_{12} \text{H}_4 \text{}^{35}\text{Cl}_8 \text{}^{37}\text{Cl}_4$	$^{13}\text{C}_{12}$ Cl-10 PCB

1. Isotopic masses used for accurate mass calculation

^1H	1.0078
^{12}C	12.0000
^{13}C	13.0034
^{35}Cl	34.9689
^{37}Cl	36.9659
^{19}F	18.9984